

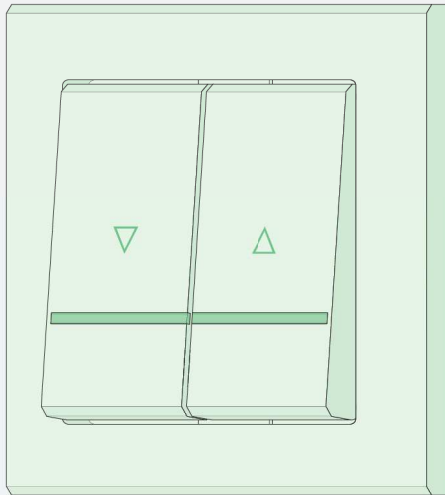

ZKP

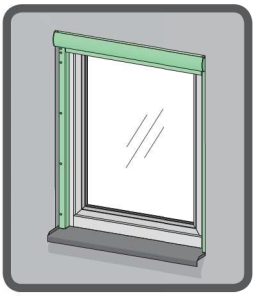

NC 888_ZKP_20.03.02_FAKRO_KB2137

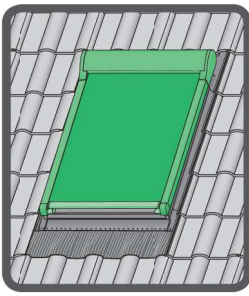
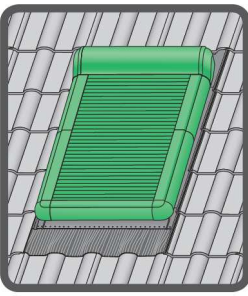
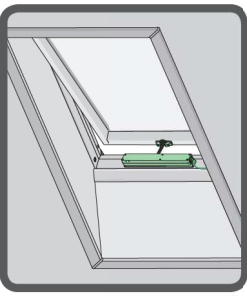

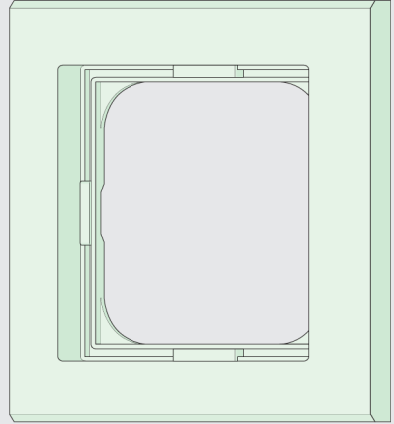
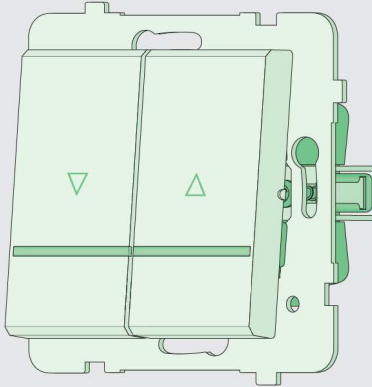

1

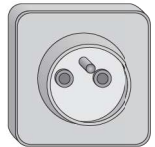
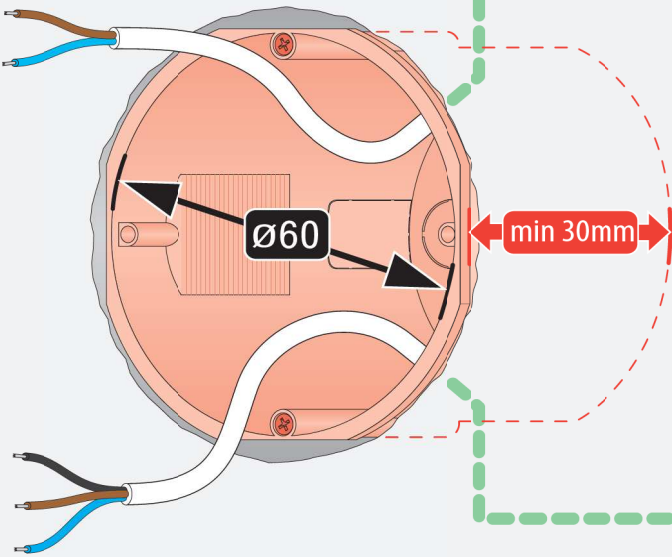

~230V



- FTP-V ELECTRO 230
- ARZ Electro 230
- AMZ Electro 230
- VMZ Electro 230
- VML Electro 230
- VMB Electro 230
- ZC230

2

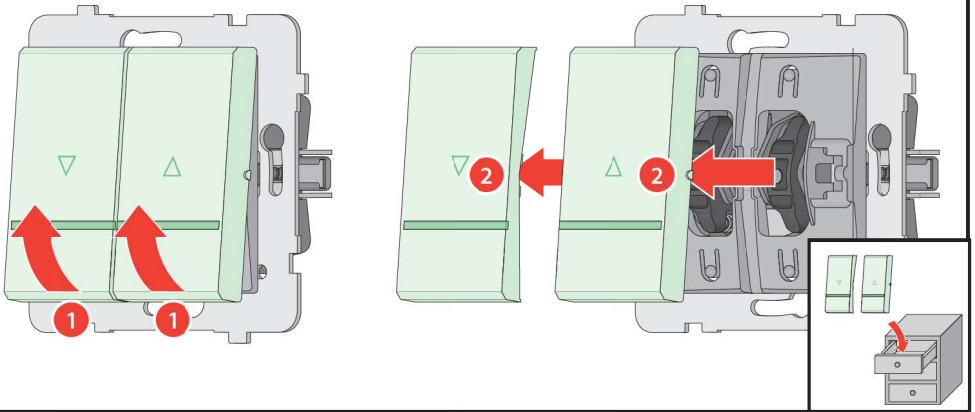

3a

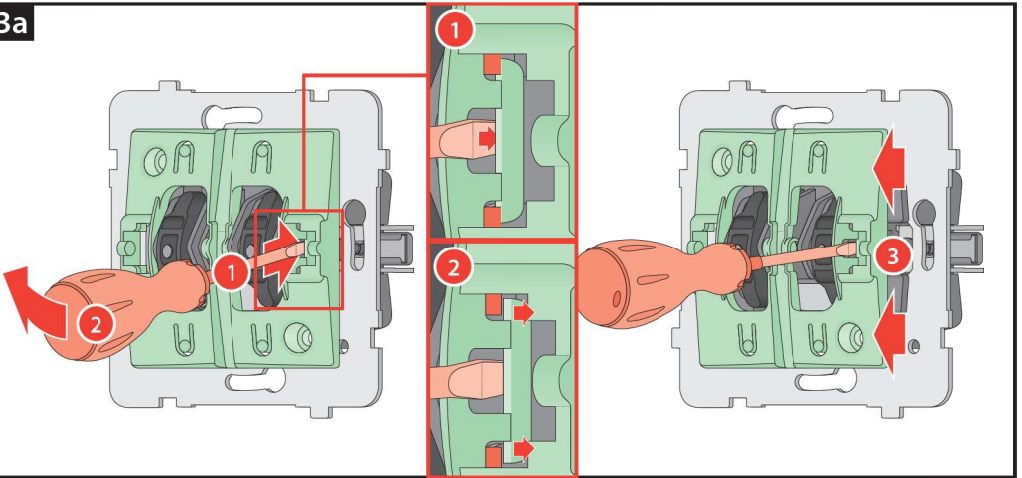

3b

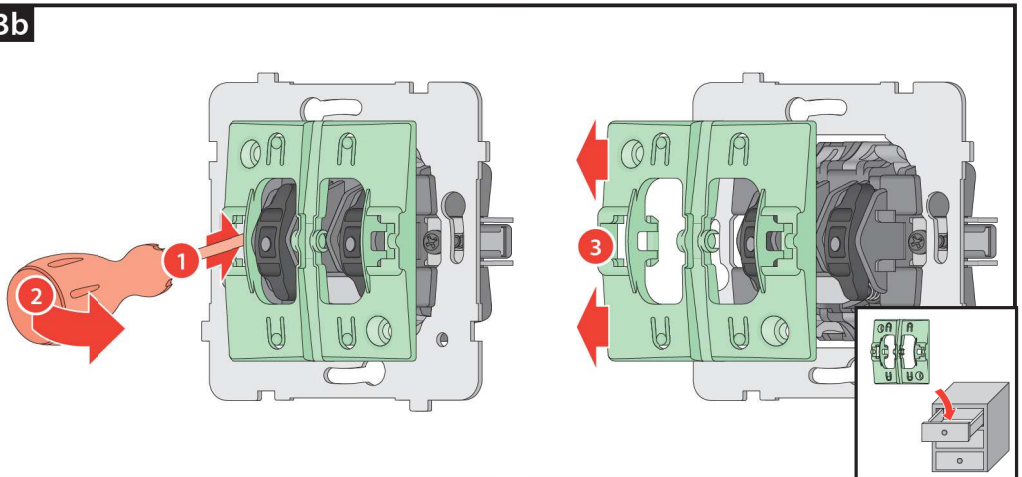

4a

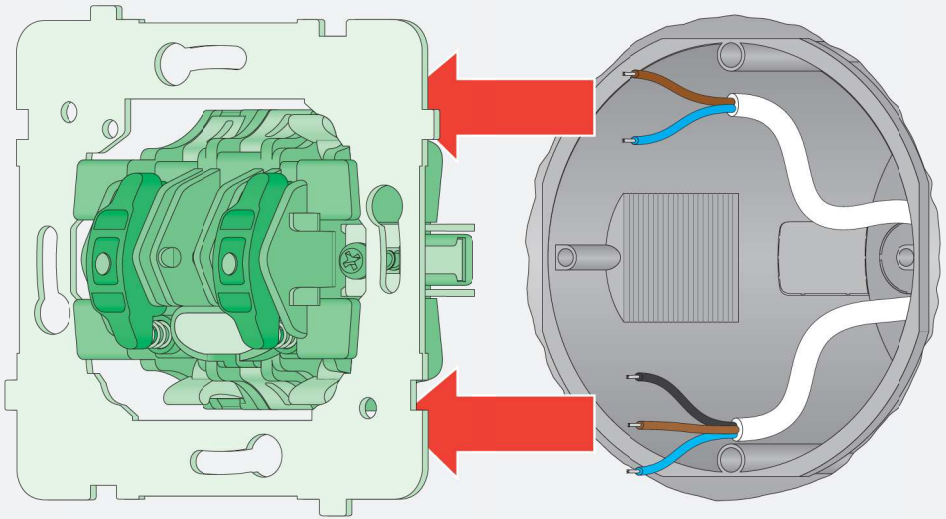

- 
- FTP-V ELECTRO 230
 - ARZ Electro 230
 - AMZ Electro 230
 - VMZ Electro 230
 - VML Electro 230
 - VMB Electro 230
 - ZC230

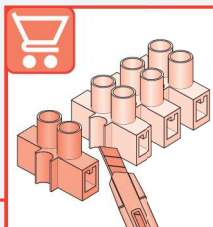
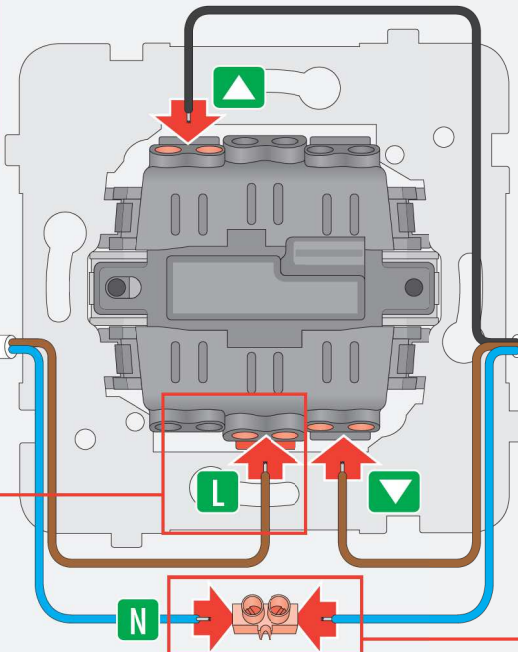
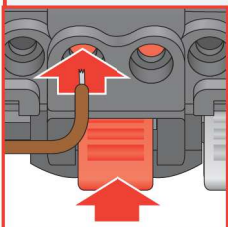

4b

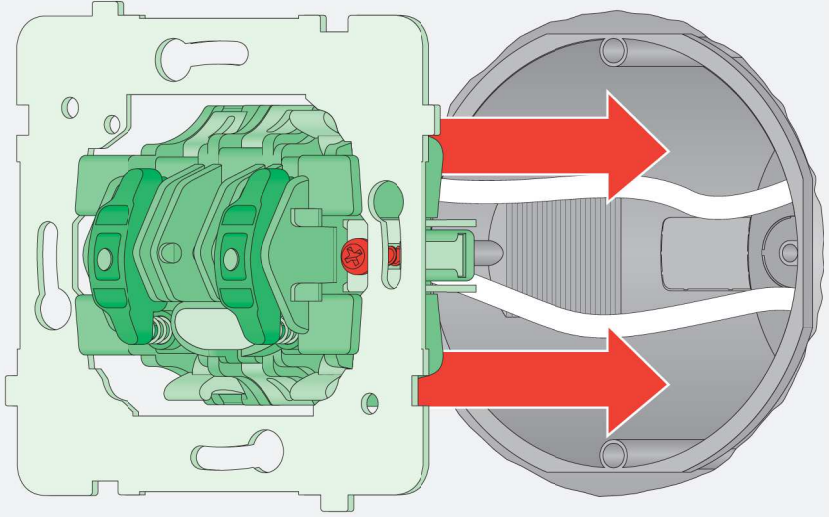

1

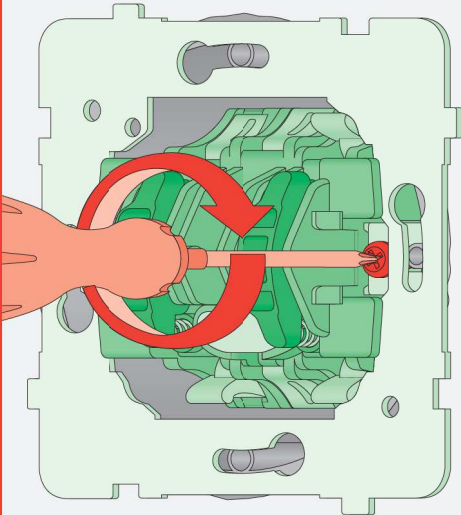

2

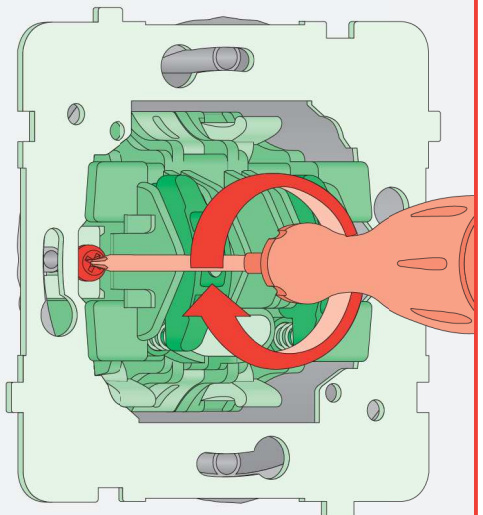

5a

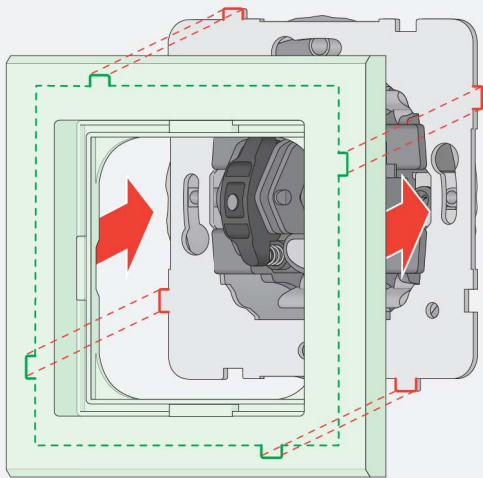

5b

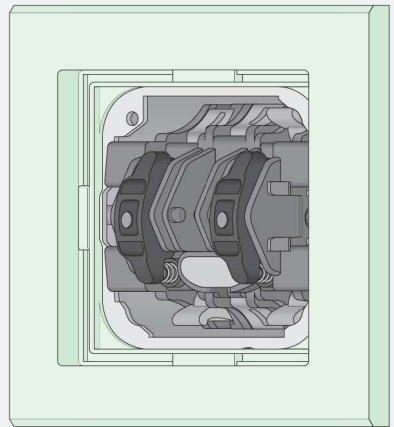

6a

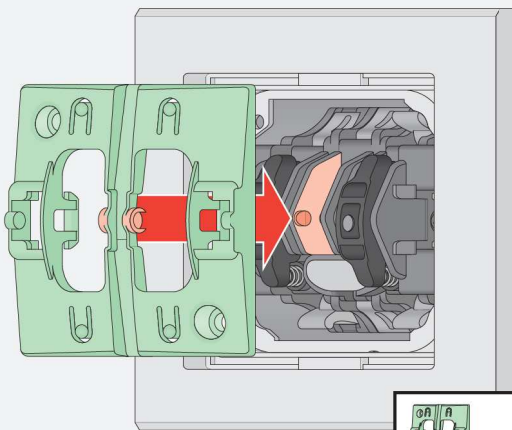

6b

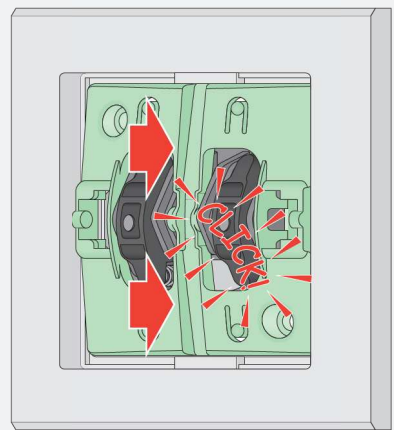

7a

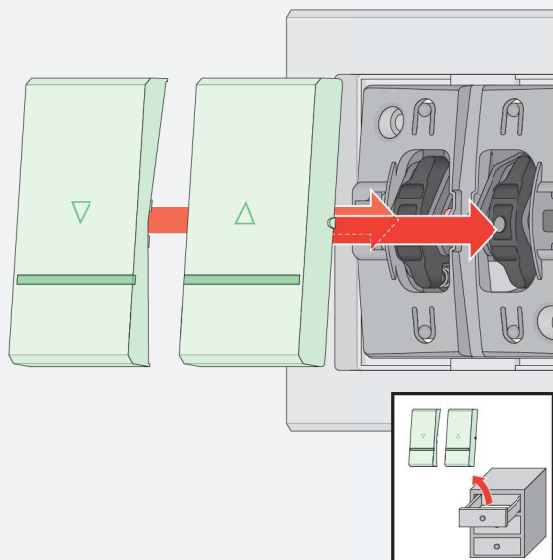

7b

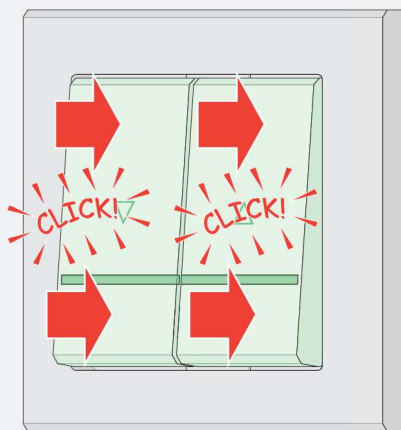

8

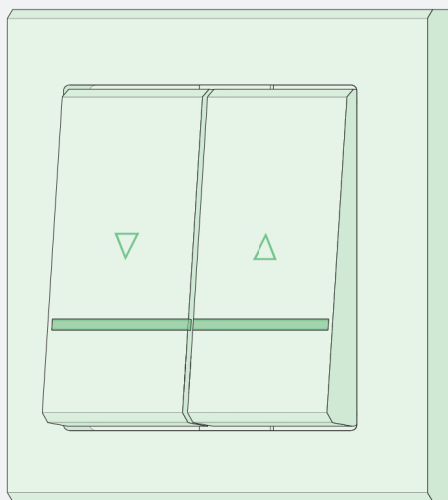

0 [cm] 1 2 3 4 5 6 7 8 9 10 11 12

BG	Производители / Продаван не носят отговорност за неспазване на съответните закони, строителни норми и изисквания за безопасност от потребителя на продукта, архитекта, монтажника или собственика на сградата.	IT	Il Produttore e il Rivenditore non potranno essere ritenuti responsabili per il mancato rispetto, da parte dell'utente del prodotto, del progettista, dell'installatore o del proprietario dell'edificio, delle leggi vigenti, nonché dei regolamenti edilizi e di quelli relativi alla sicurezza.
CZ	Utvůbce ani prodávce nenesou žádnou odpovědnost za nedodržení platných zákonů, stavebních předpisů a bezpečnostních požadavků uživatelem výrobku, architektem, montážníkem nebo vlastníkem budovy.	NL	De fabrikant en verkoper zijn niet aansprakelijk voor gevolgen bij het niet opvolgen van toepasselijke wetten, bouwbestanden en veiligheidsvoorschriften door de gebruiker van het product, de architect, de installateur of de eigenaar van het gebouw.
DE	Hersteller und Verkäufer übernehmen keine Haftung für Nichtbeachtung entsprechender Rechts- und Bauvorschriften sowie Sicherheitsanforderungen seitens Produktbenutzer, Architekten, Monteure oder Gebäudebesitzer.	PL	Producent i Sprzedawca nie ponosi żadnej odpowiedzialności za nieprzestrzeganie stosownych przepisów prawa, przepisów budowlanych i wymogów bezpieczeństwa przez użytkownika produktu, architekta, montażystę lub właściciela budynku.
ES	El fabricante y el vendedor no tienen ninguna responsabilidad por el incumplimiento de la ley vigente, normas de construcción y exigencias de seguridad por parte del usuario del producto, arquitecto, instalador o el propietario del edificio.	PT	O fabricante e o vendedor não tem nenhuma responsabilidade pelo o não cumprimento da lei, códigos de construção e as exigências de segurança por parte do usuário do produto, arquiteto, instalador ou proprietário do edifício.
FR	Le fabricant et le vendeur ne prend aucune responsabilité de ne pas respecter les lois applicables, les règlements sur les bâtiments et les exigences de sécurité par l'utilisateur du produit, l'architecte, l'installateur ou le propriétaire du bâtiment.	RO	Nici producătorul, nici distribuitorul nu își vor asuma nici un fel de răspundere pentru nerespectarea legilor în vigoare a legilor din domeniul construcțiilor sau a măsurilor de siguranță impuse utilizatorilor produsului, arhitecților, montajorilor sau proprietarilor clădirii.
GB	Manufacturer and Sellers shall bear no liability for failure to comply with the applicable laws, building codes and safety requirements by the user of the product, architect, fitter or owner of the building.	RU	В случае несоблюдения архитектором, монтажником или владельцем здания строительных правил и норм безопасности ответственность с производителя и продавца снимается.
HU	A gyártó és a forgalmazó nem vállal semmilyen felelősséget a vonatkozó törvények, építési és biztonsági előírások, stb. nem tartásáért.	SK	Vníkajú a predávajúci nenesú žiadnu zodpovednosť za nedodržanie príslušných ustanovení zákona, stavebných predpisov a bezpečnostných požadavkov užívateľom výrobku, architektom, montérom alebo majiteľom objektu.