

12 ORIGINALNÍ NÁVOD 2/3 Pravidla pro instalaci a použití  
11 ORIGINALANLEITUNG 2/3 Montage- und Nutzungsregeln  
10 ORIGINAL INSTRUCTIONS 2/3 Installation and user manual  
9 MANUEL ORIGINAL 2/3 Règles de montage et d'utilisation  
8 INSTRUKCJA ORYGINALNA 2/3 Zasady montażu i użytkowania

 **FAKRO**<sup>®</sup>

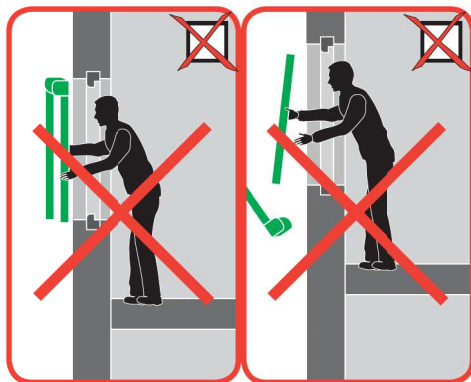

# VMZ Z-Wave

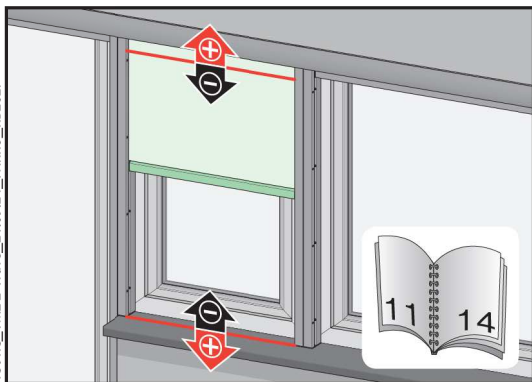
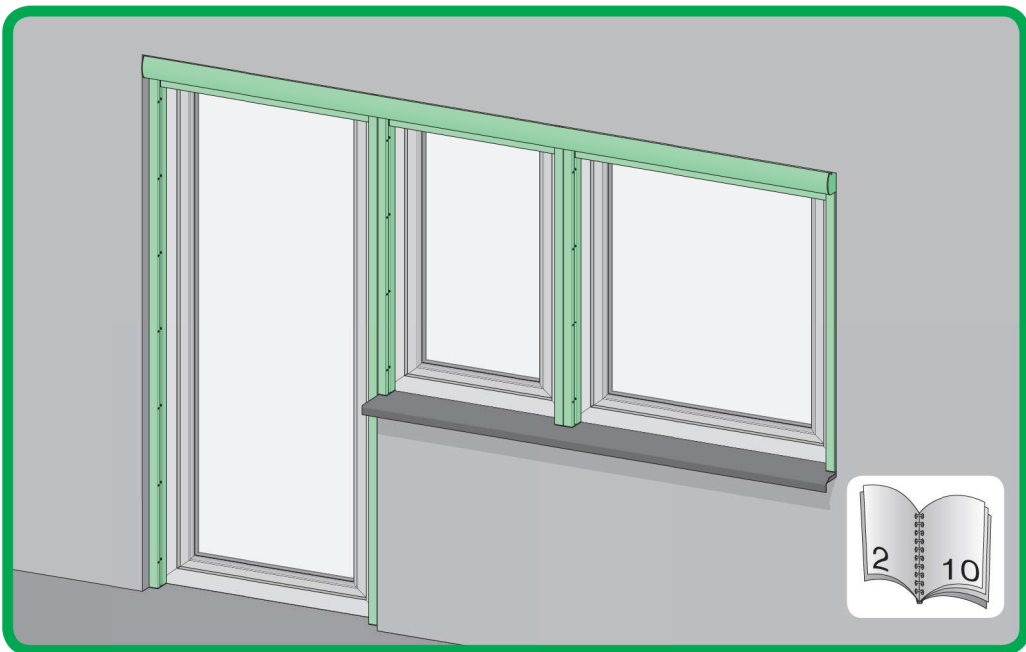

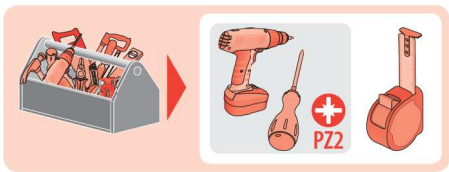

**1a**  3mm

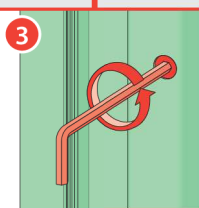
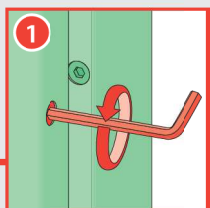
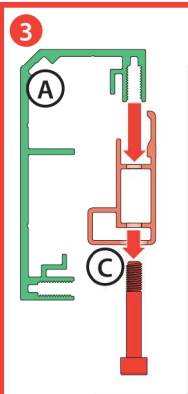
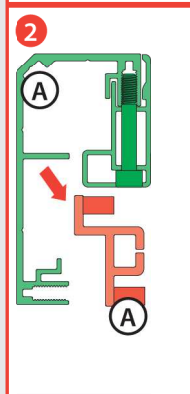
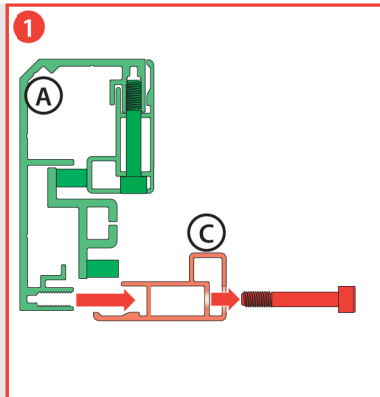
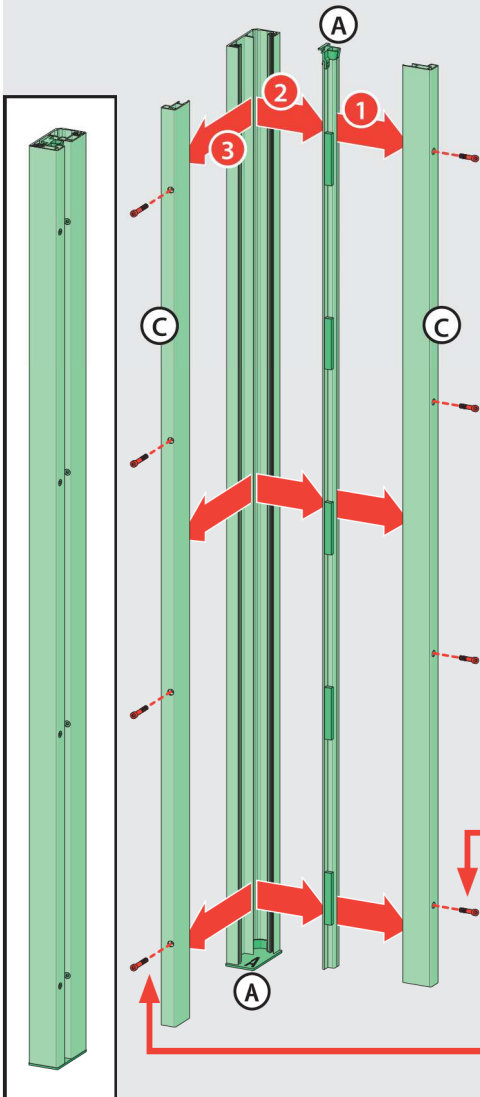

**1b**

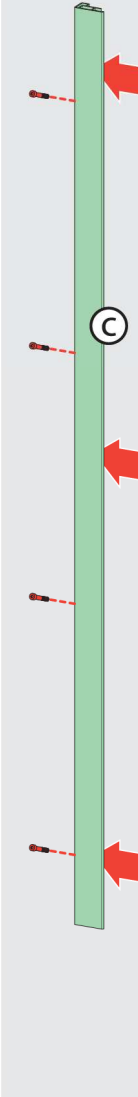

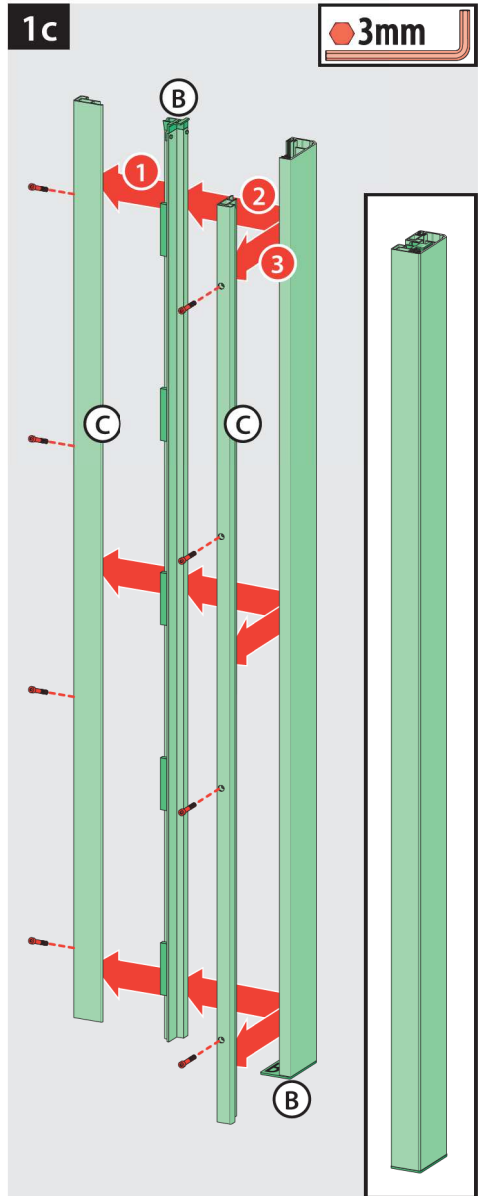
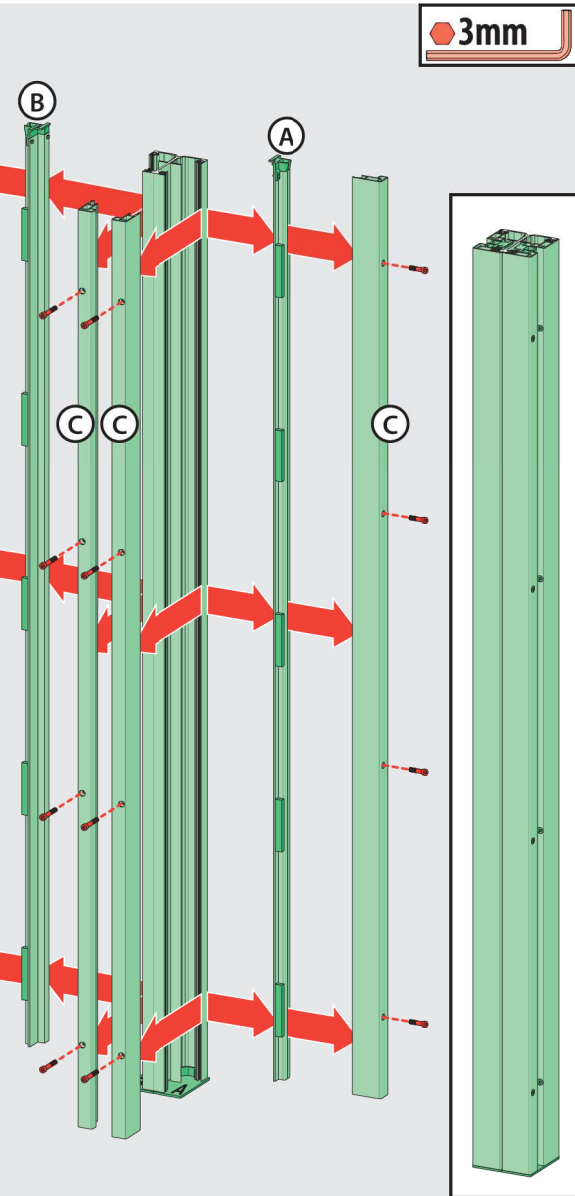
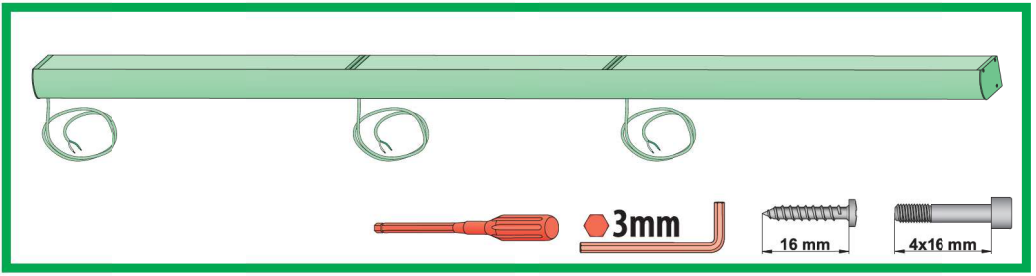

2

4x16 mm 3mm

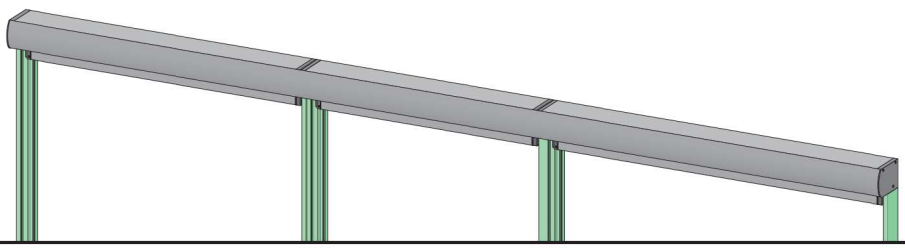
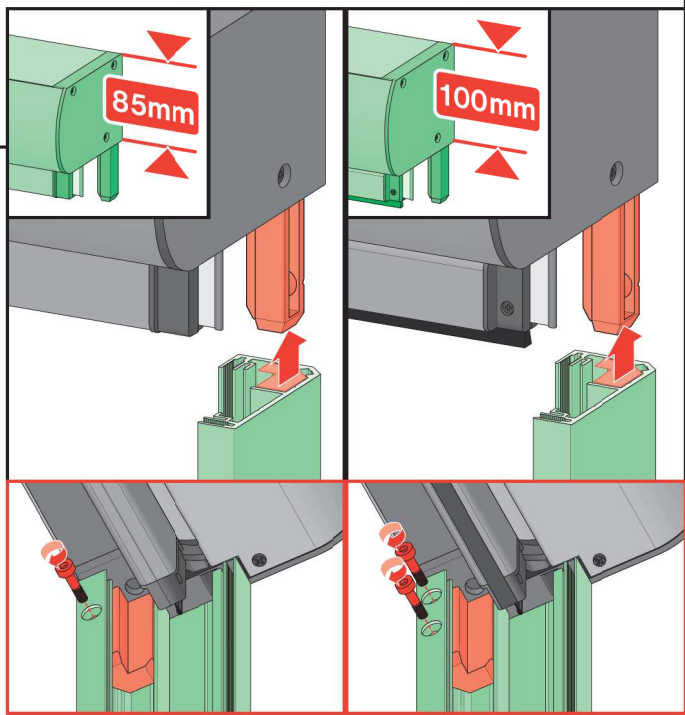
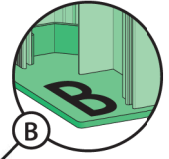
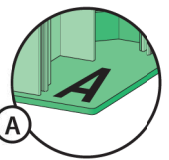

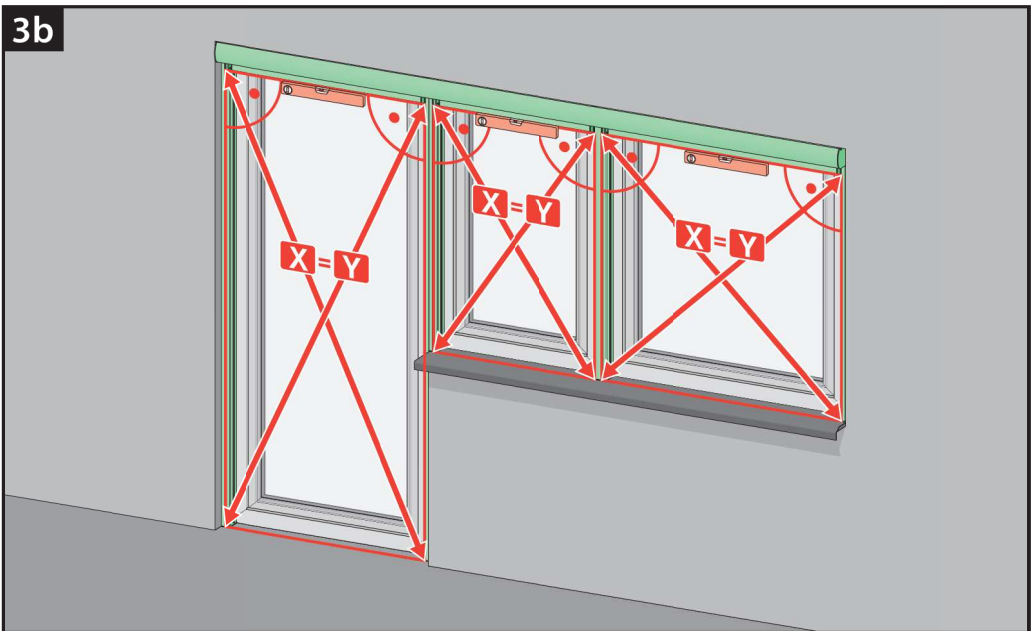
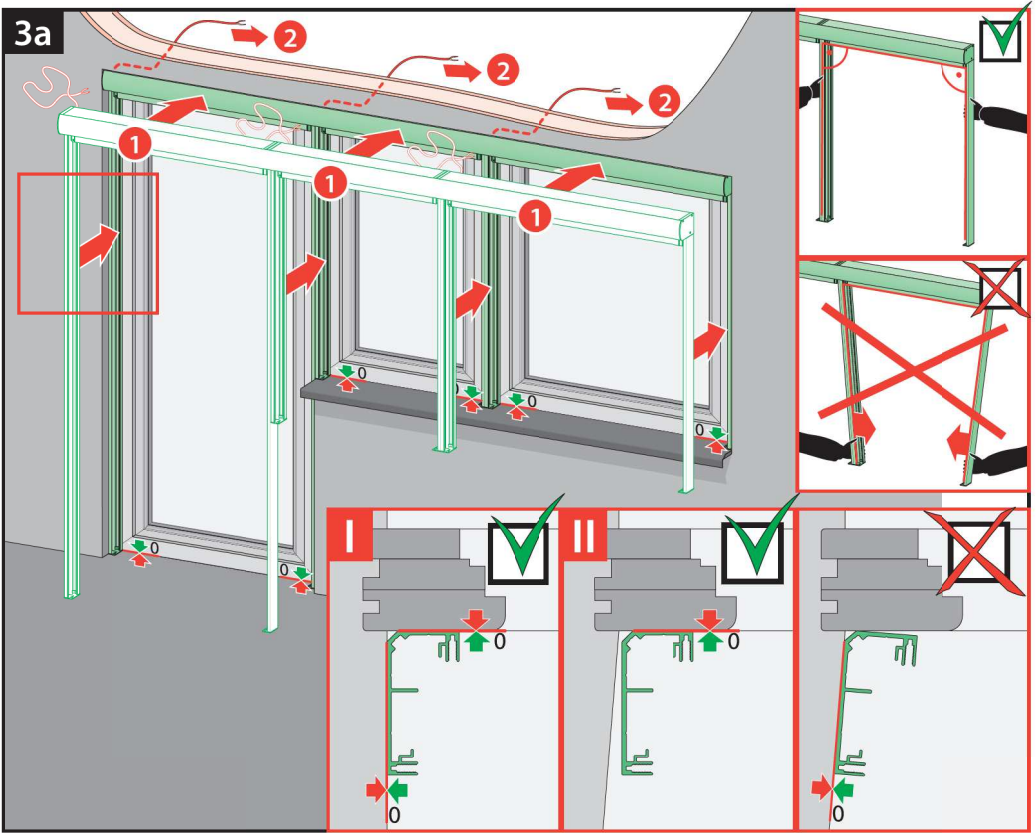

4

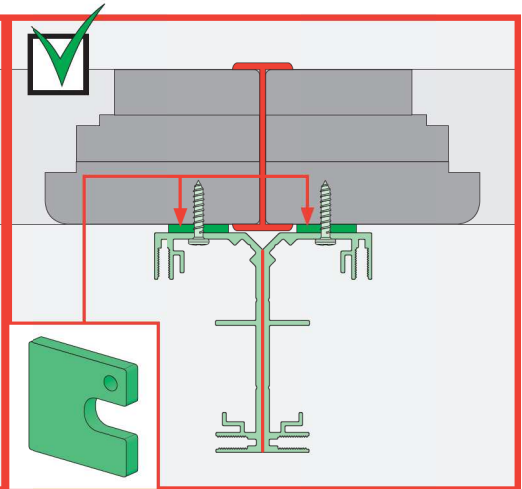
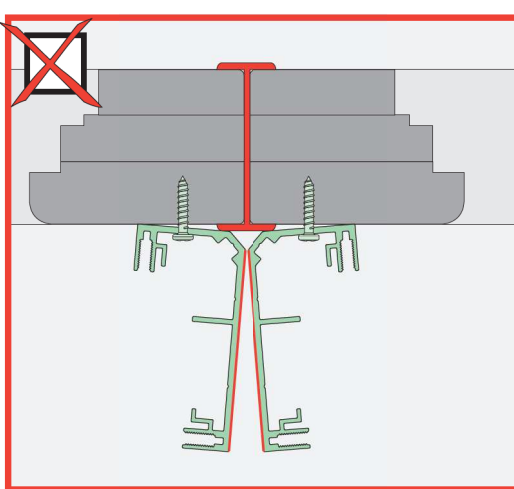
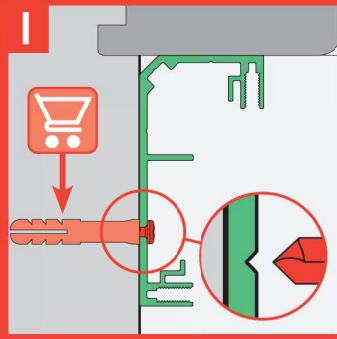
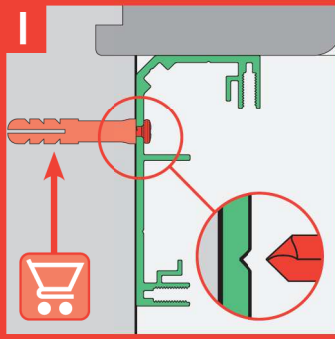
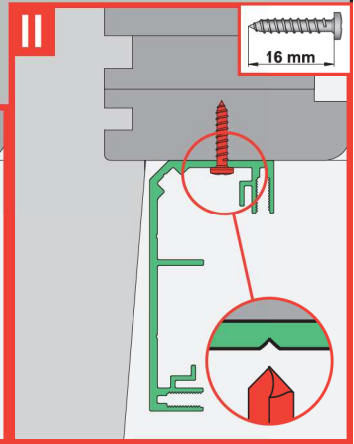
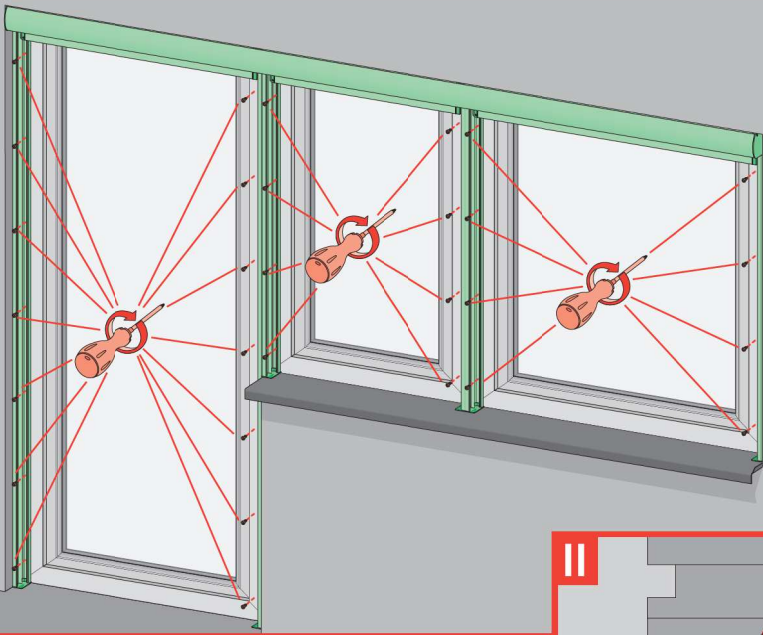

5a

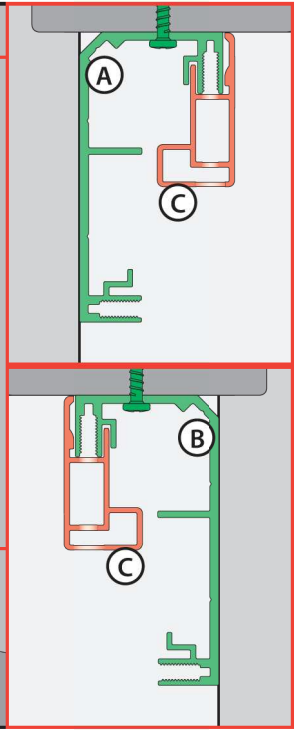
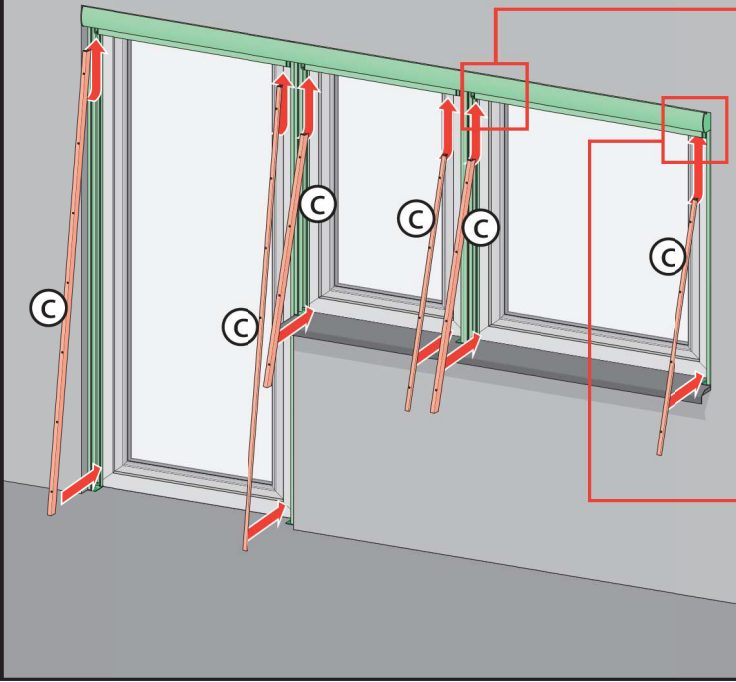

5b

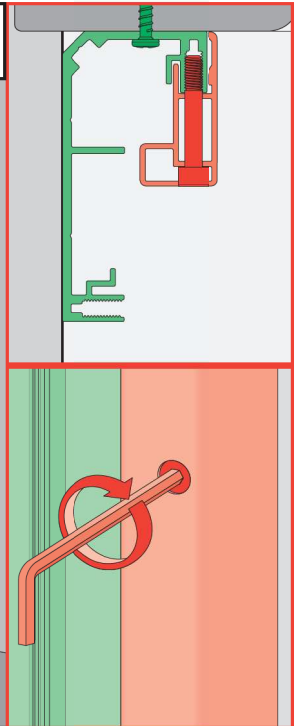
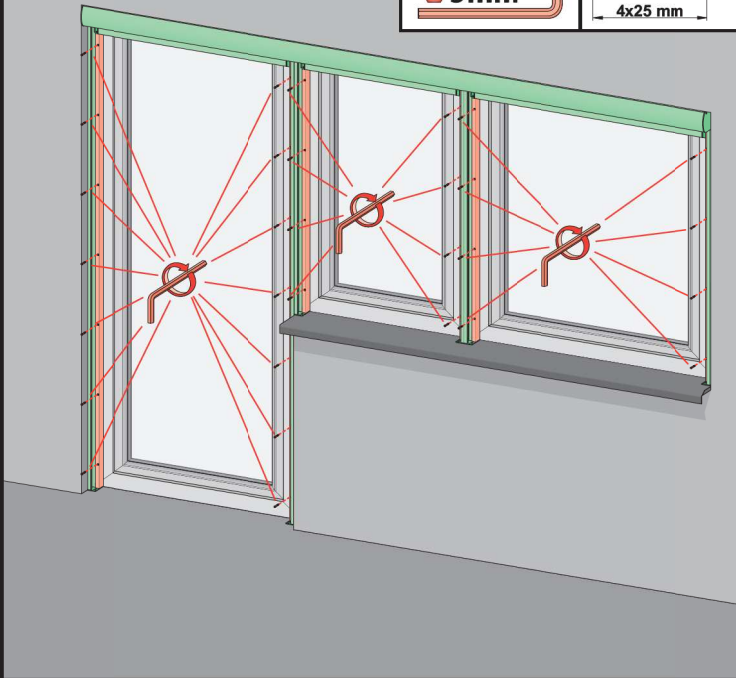

6a

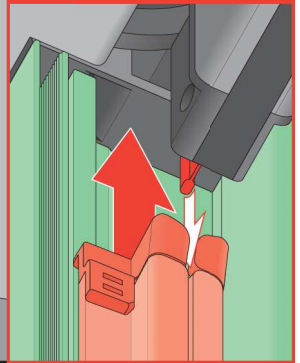
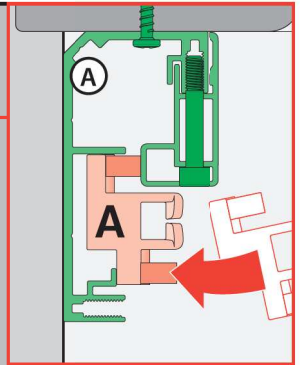
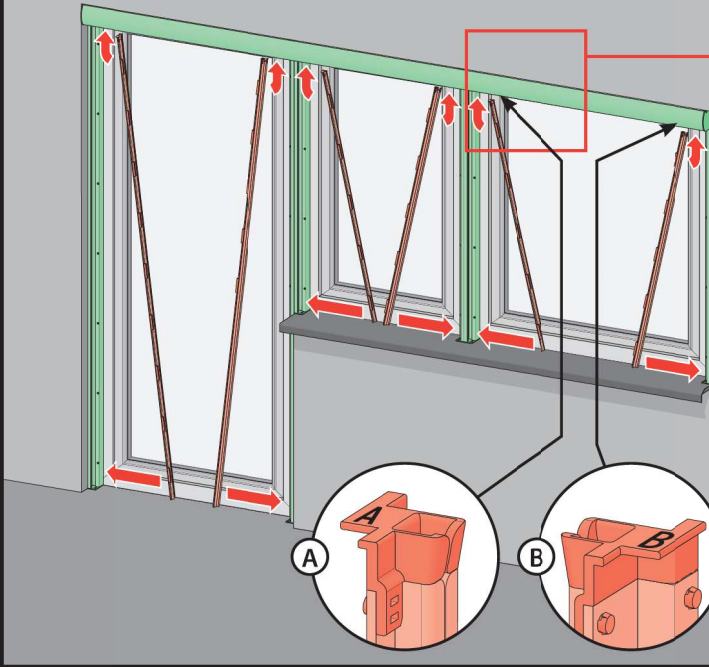

6b

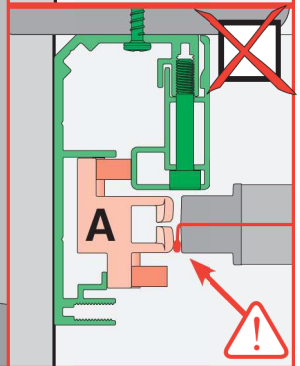
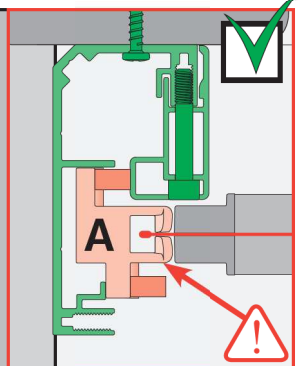
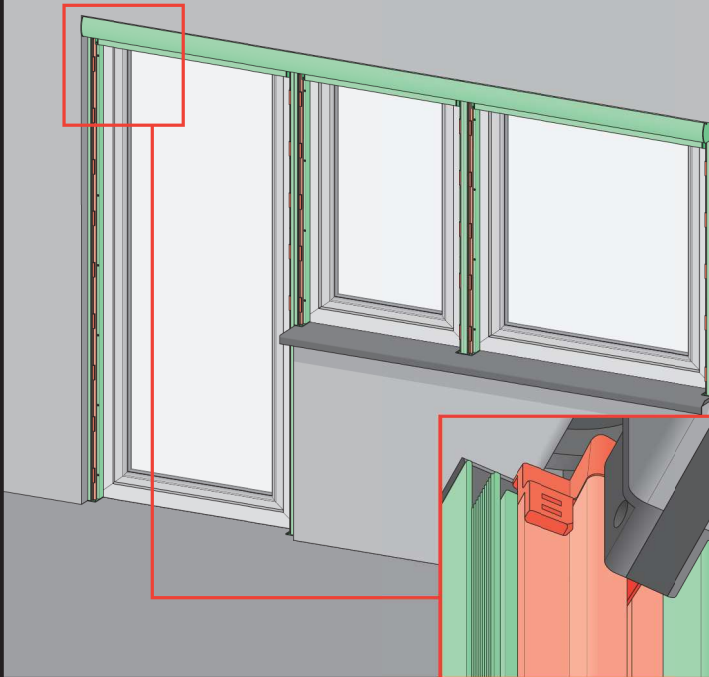

7a

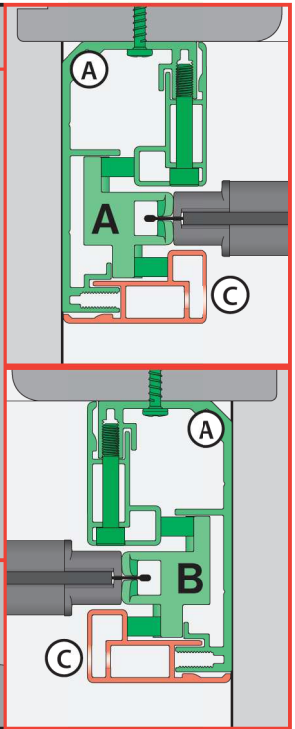
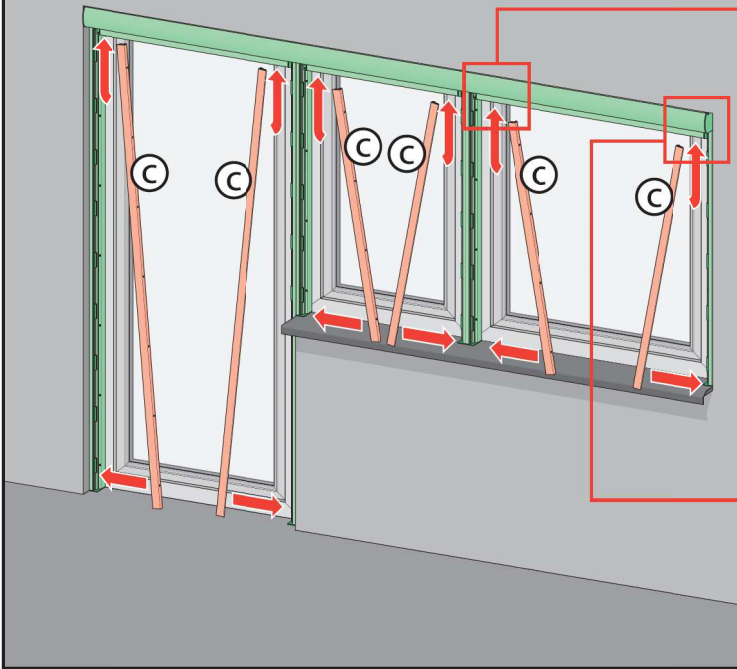

7b

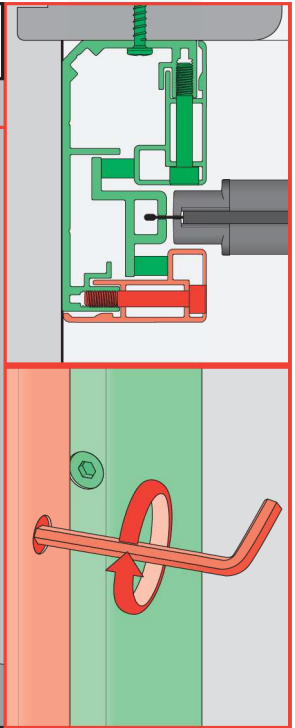
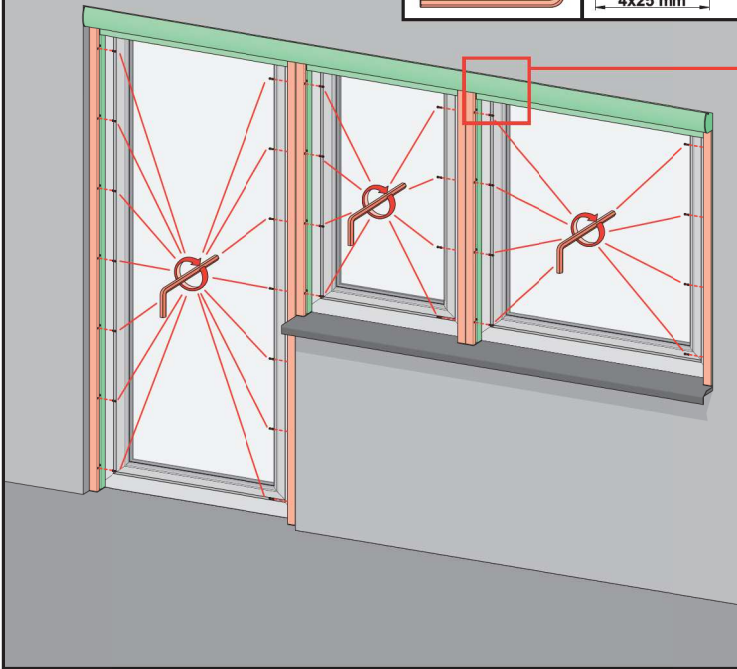

8a

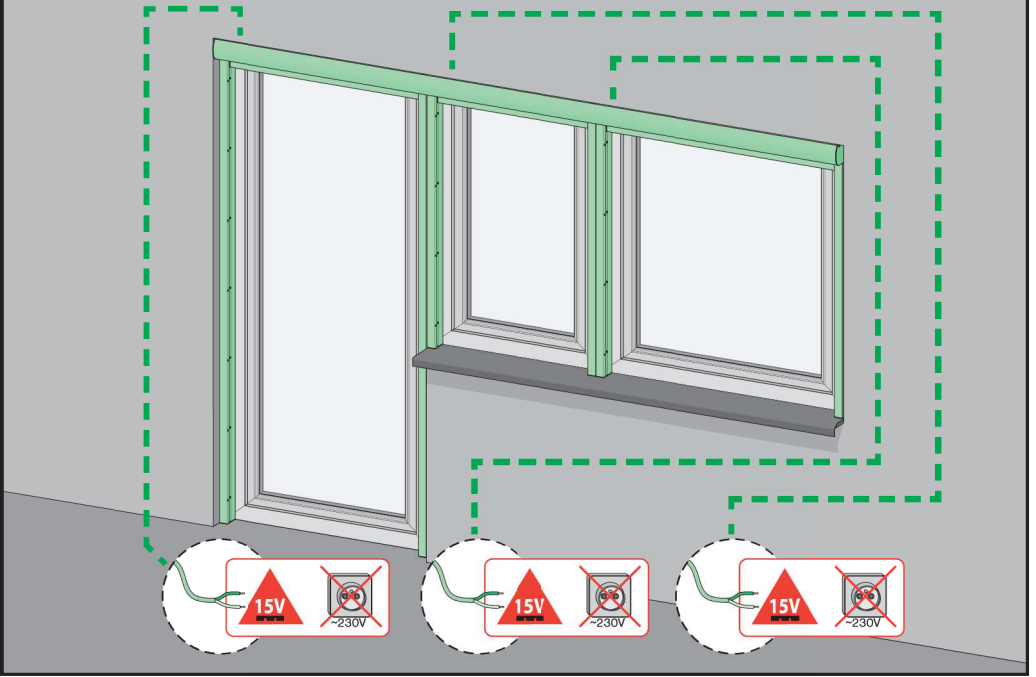

8b

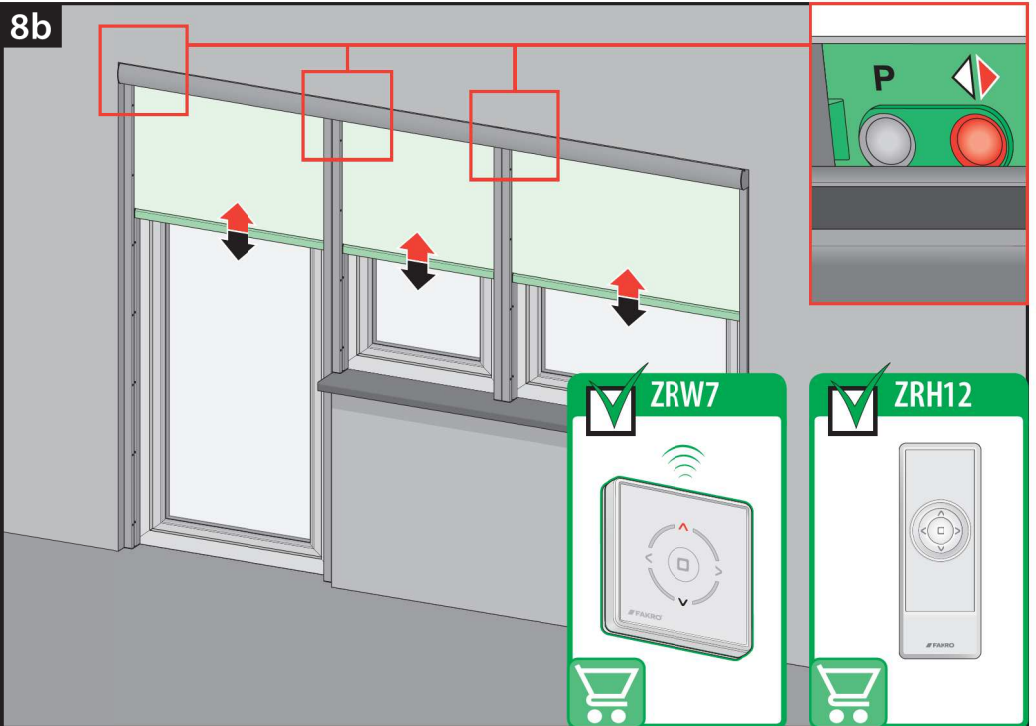

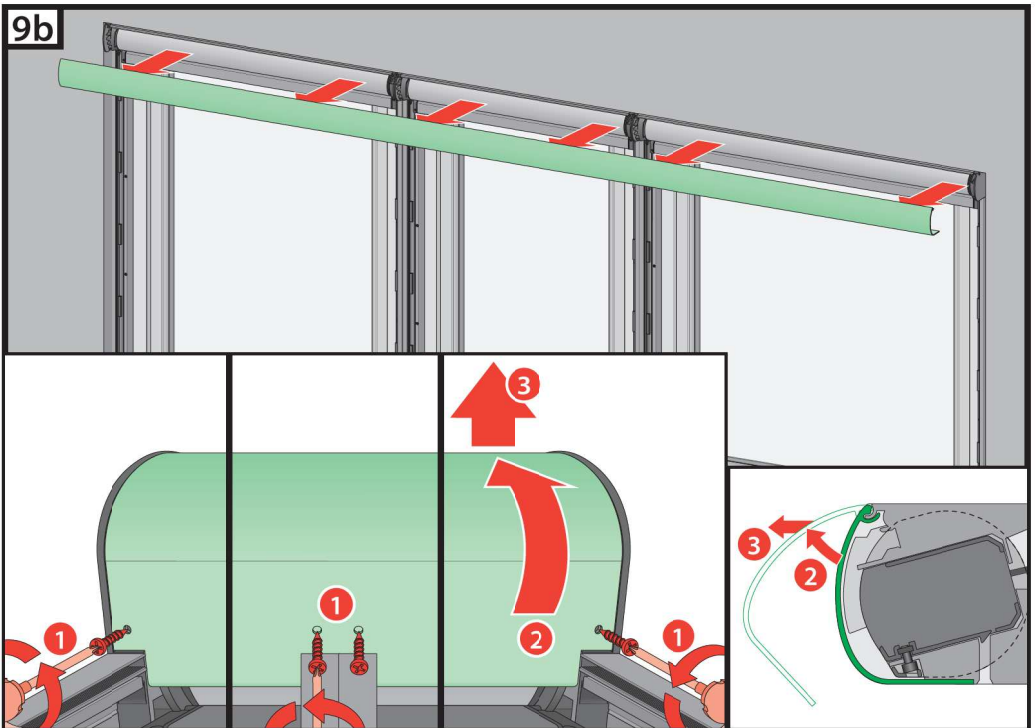
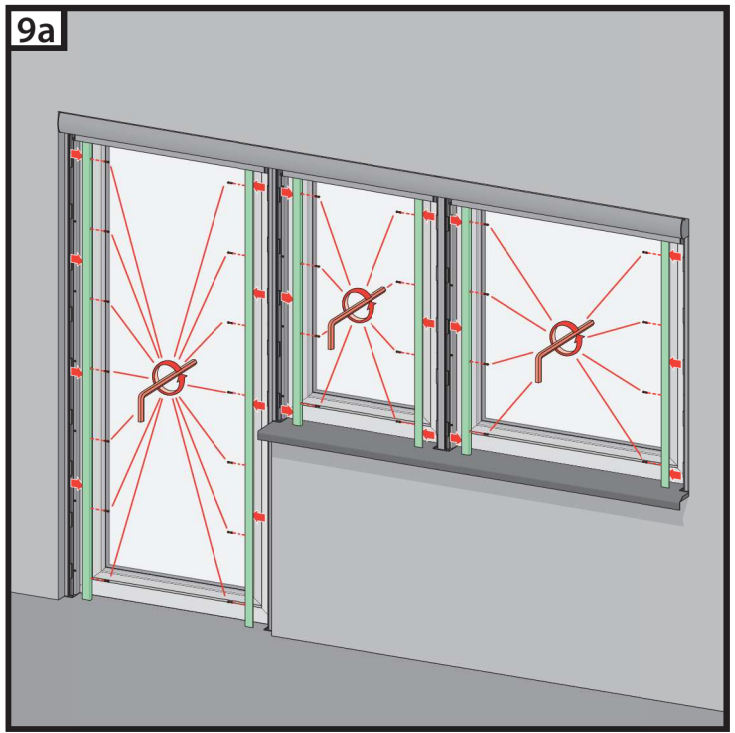
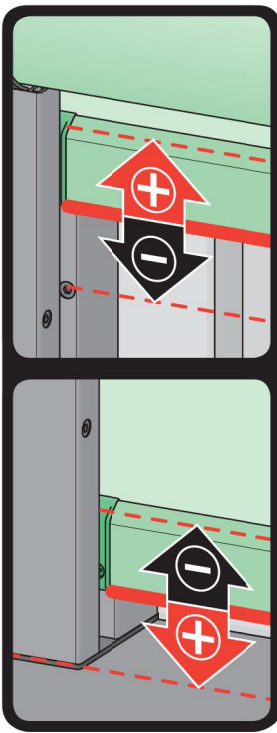

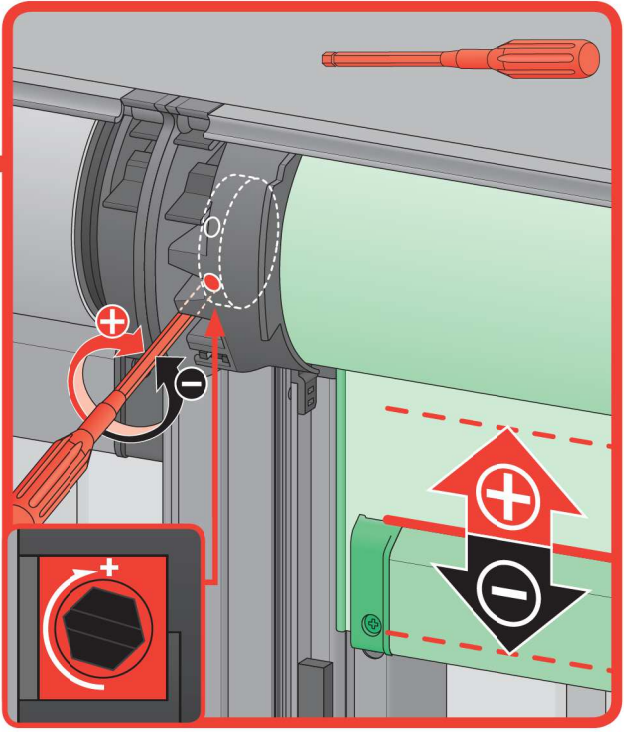
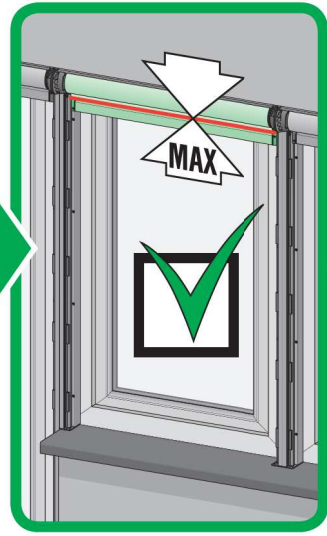
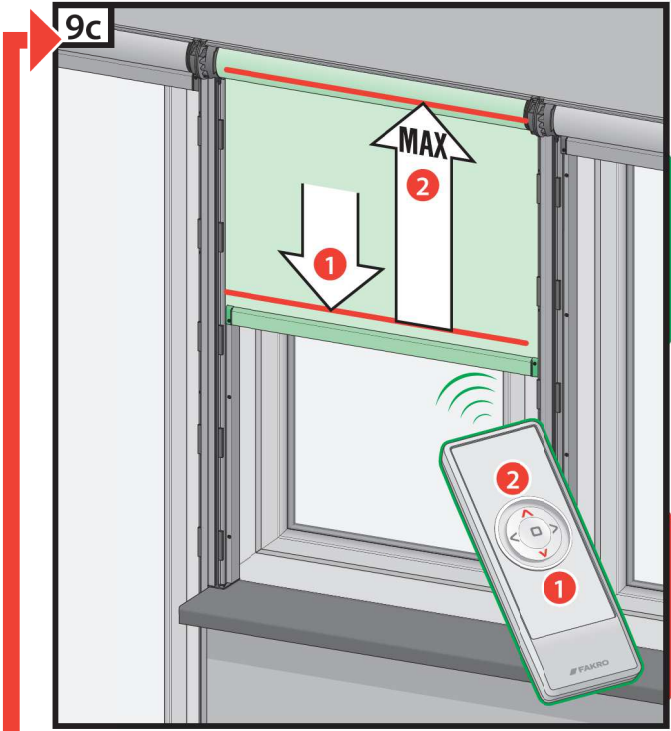

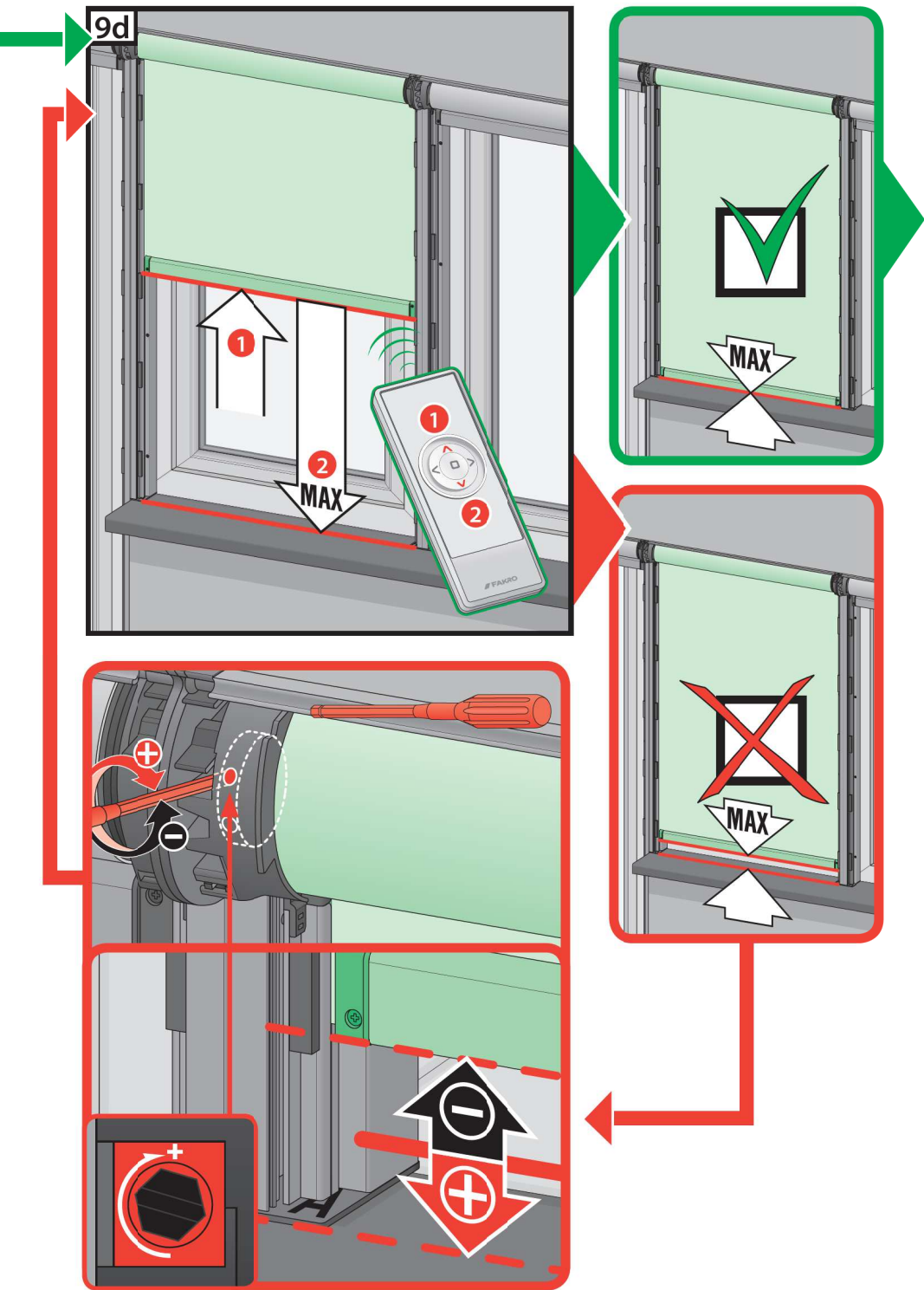

9e

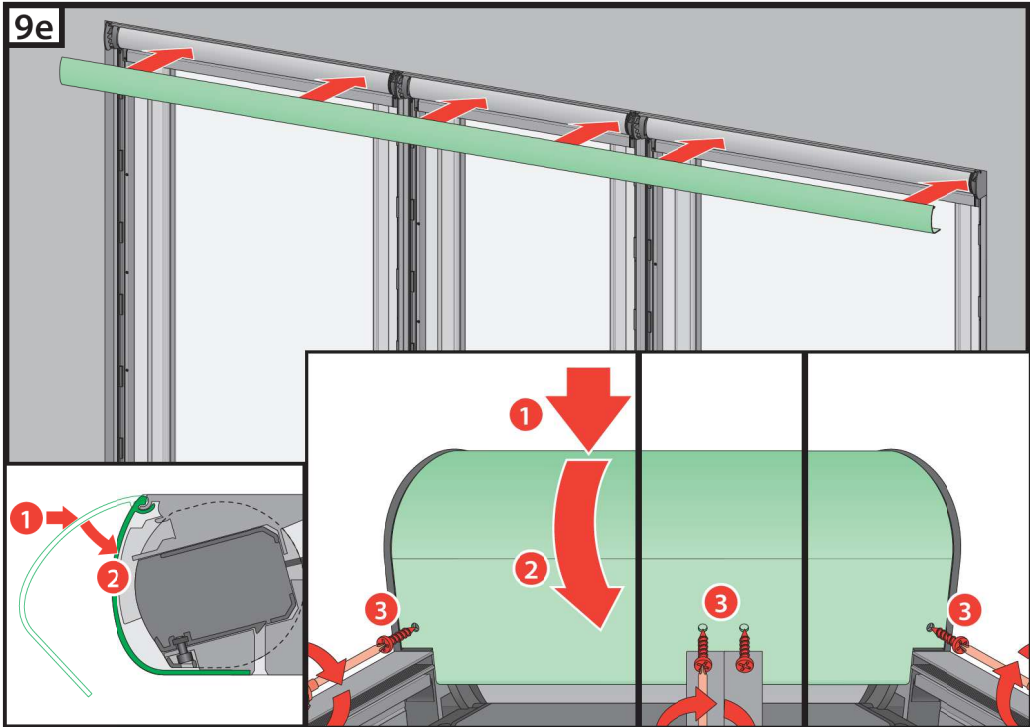

9f

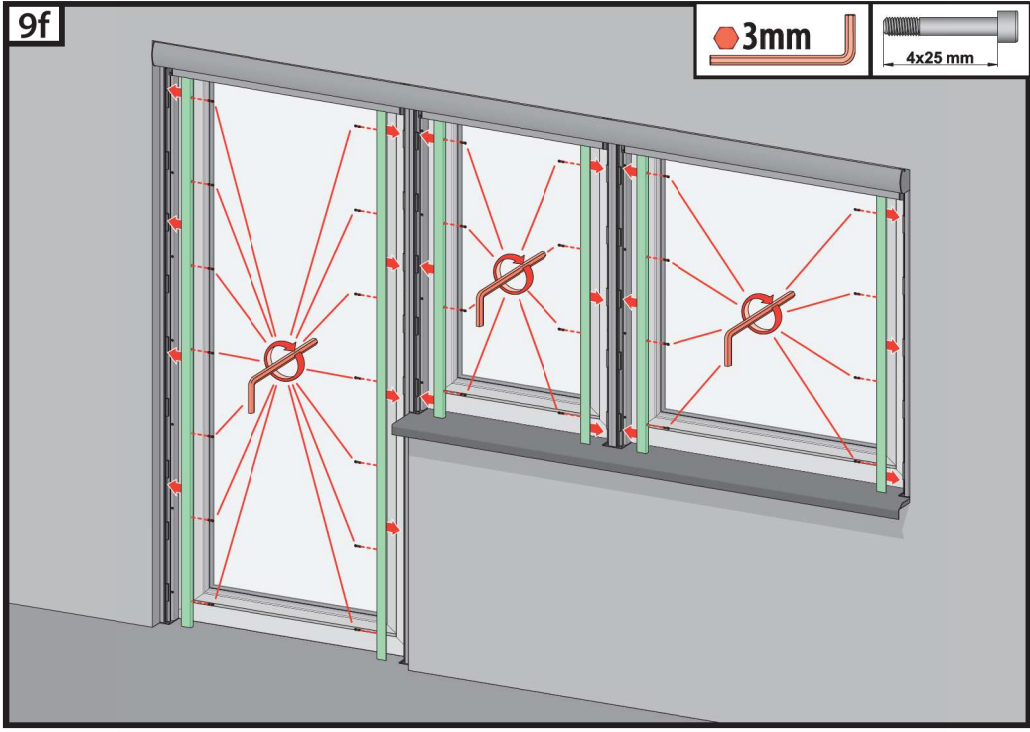

<b>CZ</b>	Před montáží si pozorně přečtěte návod NC9RC „ORIGINÁLNÍ NÁVOD 2/3 Pravidla pro instalaci a použití“.
1a, 1b, 1c	Odmontujte krycí a plastové profily z vodících lišt.
2	Spojte boční vodící lišty s kazetou markýzy.
3a	Umístěte markýzu do okenního otvoru.
3b	Zkontrolujte správnost montáže markýzy.
4	Přišroubujte markýzu k oknu nebo k ostění.
5a	Vložte záslepky do otvorů vodících lišt.
5b	Přišroubujte krycí profily.
6a	Vložte plastové vodící lišty do bočních vodících lišt.
6b	Dávejte pozor na správné umístění zipu ve vodící liště.
7a	Nasaděte vnější krycí profily na vodící lišty.
7b	Přišroubujte krycí profily.
8a	Připojte markýzu k napájení.
8b	Ovládejte markýzu pomocí dálk. ovladače nebo ovládacího tlačítka.
9a, 9b, 9c, 9d, 9e, 9f	V případě potřeby proveďte regulaci koncových poloh markýzy.

<b>FR</b>	Avant le montage, lire l'instruction NC9RC "INSTRUCTION ORIGINALE 2/3 Règles de montage et d'utilisation ".
1a, 1b, 1c	Retirez les profilés de recouvrement et les glissières en plastique des glissières.
2	Connectez les glissières latéraux à la cassette de store.
3a	Placez le store dans l'ouverture de la fenêtre.
3b	Vérifiez si le store est correctement installé.
4	Visser le store à la fenêtre ou à l'encadrement.
5a	Placez les profilés de recouvrement dans les glissières.
5b	Visser les profilés de recouvrement.
6a	Placez les glissières en plastique dans les glissières latérales.
6b	Assurez-vous que le verrou est correctement positionné dans la glissière.
7a	Placez les profilés de recouvrement extérieures dans les glissières.
7b	Visser les profilés de recouvrement.
8a	Connectez le store à l'alimentation électrique.
8b	Commandez le store avec la télécommande ou les boutons du contrôleur.
9a, 9b, 9c, 9d, 9e, 9f	Si nécessaire, ajustez les positions finales du store.

<b>DE</b>	Lesen Sie vor der Montage die Anweisungen NC9RC "ORIGINALANLEITUNG 2/3 Montage- und Nutzungsregeln"
1a, 1b, 1c	Demontieren Sie die Abdeckprofile und Kunststoffführungen von den Führungsschienen.
2	Verbinden Sie die Seitenführungen mit Markisenkassette.
3a	Stellen Sie die Markise in die Fensteröffnung.
3b	Überprüfen Sie die korrekte Montage der Markise.
4	Schrauben Sie die Markise ans Fenster oder ans Innenfutter.
5a	Legen Sie die Abdeckprofile in die Führungsschienen.
5b	Deckenprofile anschrauben.
6a	Setzen Sie die Kunststoffführungen in die Seitenführungen ein.
6b	Stellen Sie sicher, dass das Schloss richtig in der Führung positioniert ist.
7a	Legen Sie die äußeren Maskierungsprofile in die Führungen.
7b	Deckenprofile anschrauben.
8a	Schließen Sie die Markise an die Stromversorgung an.
8b	Steuern Sie die Markise mit der Fernbedienung oder den Tasten auf der Steuerung.
9a, 9b, 9c, 9d, 9e, 9f	Passen Sie gegebenenfalls die Endpositionen der Markise an.

<b>EN</b>	Before installation, it is compulsory to read the NC9RC „ORIGINAL INSTRUCTIONS 2/3 Installation and user manual“.
1a, 1b, 1c	Remove the cover strips and plastic guide rails from the guide rails.
2	Connect the side guide rails to the awning cassette.
3a	Place the awning in the window opening.
3b	Check the correctness of the awning installation.
4	Screw the awning to the window or to the lining.
5a	Place the cover strips in the guide rails.
5b	Screw the cover strips.
6a	Place the plastic guide rails in the side guide rails.
6b	Make sure that the lock is properly positioned in the guide rail.
7a	Place the outer cover strips in the guide rails.
7b	Screw the cover strips.
8a	Connect the awning to the power supply.
8b	Operate the awning using remote control or buttons on the awning.
9a, 9b, 9c, 9d, 9e, 9f	If required, adjust the end positions of the awning.

PL	Przed montażem należy zapoznać się z treścią instrukcji NC9RC „INSTRUKCJA ORYGINALNA 2/3 Zasady montażu i użytkowania”.
1a, 1b, 1c	Zdemontować profile maskujące oraz prowadnice tworzywowe z przewodnic.
2	Połączyć prowadnice boczne z kasetą markizy.
3a	Umieścić markizę w otworze okiennym.
3b	Sprawdzić poprawność montażu markizy.
4	Przykręcić markizę do okna lub do szpalety.
5a	Umieścić profile maskujące w prowadnicach.
5b	Przykręcić profile maskujące.
6a	Umieścić prowadnice tworzywowe w prowadnicach bocznych.
6b	Zwrócić uwagę na prawidłowe umieszczenie zamka w prowadnicy.
7a	Umieścić zewnętrzne profile maskujące w prowadnicach.
7b	Przykręcić profile maskujące.
8a	Podłączyć markizę do zasilania.
8b	Sterować markizą za pomocą pilota lub przycisków na sterowniku.
9a, 9b, 9c, 9d, 9e, 9f	W razie potrzeby przeprowadzić regulację pozycji krańcowych markizy.



BG	Производител и Продавач не носят отговорност за неспазване на съответните закони, строителни норми и искания за безопасност от потребителя на продукта, архитекта, монтажника или собственика на сградата.	IT	Il Produttore e il Rivenditore non potranno essere ritenuti responsabili per il mancato rispetto, da parte dell'utente del prodotto, del progettista, dell'installatore o del proprietario dell'edificio, delle leggi vigenti, nonché dei regolamenti edilizi e di quelli relativi alla sicurezza.
CZ	Utvůrce ani prodávce nenesou odpovědnost za nedodržení příslušných právních zákonů, stavebních předpisů a bezpečnostních požadavků uživatelem výrobku, architektem, montážníkem nebo vlastníkem budovy.	NL	De fabrikant en verkoper zijn niet aansprakelijk voor gevolgen bij het niet opvolgen van toepasselijke wetten, bouwbesluiten en veiligheidsvoorschriften door de gebruiker van het product, de architect, de installator of de eigenaar van het gebouw.
DE	Hersteller und Verkäufer übernehmen keine Haftung für Nichtbeachtung entsprechender Rechts- und Bauvorschriften sowie Sicherheitsanforderungen seitens Produktbenutzers, Architekten, Monteurs oder Gebäudebesitzer.	PL	Producent i Sprzedawca nie ponosi żadnej odpowiedzialności za nieprzestrzeganie stosownych przepisów prawa, przepisów budowlanych i wymogów bezpieczeństwa przez użytkownika produktu, architekta, montażystę lub właściciela budynku.
ES	El fabricante y el vendedor no tienen ninguna responsabilidad por el incumplimiento de la ley vigente, normas de construcción y exigencias de seguridad por parte del usuario del producto, arquitecto, instalador o el propietario del edificio.	PT	Ofabricante e o vendedor não tem nenhuma responsabilidade pelo o não cumprimento da lei, códigos de construção e as exigências de segurança por parte do usuário do produto, arquiteto, instalador ou proprietário do edifício.
FR	Le fabricant et le revendeur ne prend aucune responsabilité de ne pas respecter les lois applicables, les règlements en vigueur et les exigences de sécurité par l'utilisateur du produit, l'architecte, l'installateur ou le propriétaire du bâtiment.	RO	Nici producătorul, nici distribuitorul nu îi vor acuma niciun fel de răspundere pentru nerespectarea legilor în vigoare a legilor din domeniul construcțiilor sau a măsurilor de siguranță impuse utilizatorilor produsului, arhitecților, montajorilor sau proprietarilor clădirii.
GB	Manufacturer and Sellers shall bear no liability for failure to comply with the applicable laws, building codes and safety requirements by the user of the product, architect, fitter or owner of the building.	RU	В случае несоблюдения архитектором, монтажником или владельцем здания строительных правил и норм безопасности ответственность производителю и продавцу неимается.
HU	A gyártó és a forgalmazó nem vállal semmilyen felelősséget a vonatkozó törvények, építési és biztonsági előírások, stb. nem tartásáért.	SK	Vníská a predávajúci nenesú žiadnu zodpovednosť za nedodržanie príslušných ustanovení zákona, stavebných predpisov a bezpečnostných požadavkov užívateľom výrobku, architektom, montérom alebo majiteľom objektu.