

# **FIRE RESISTANCE EXPERT JUDGEMENT REPORT WITH CLASSIFICATION FIRES-JR-079-24-NURE**

---

**Horizontal shutter with folding steel ladder, type LMF60**

**Horizontal shutter with folding scissor steel ladder, type LSF60**

**Horizontal shutter with folding timber ladder, type LWF60**

This is an electronic version of the classification report, which is equivalent to the printed version. The electronic version is always issued, the printed version is issued only at the request of the sponsor. The document does not contain visual signatures of the responsible persons. The validity of the document is conditional upon a valid certified digital seal. The original file containing this document can be downloaded from the secure cloud FIRES, s.r.o., after getting the link from the sponsor. Any information listed in this document is the property of the sponsor and shall not be used or published without written permission. This file may only be modified by the editor i.e. Testing laboratory FIRES, s.r.o. Sponsor is allowed to publish this document in parts only with written permission of the editor.

# FIRE RESISTANCE EXPERT JUDGEMENT REPORT WITH CLASSIFICATION

**FIRES-JR-079-24-NURE**

**Name of the product:** Horizontal shutter with folding steel ladder, type LMF60  
Horizontal shutter with folding scissor steel ladder, type LSF60  
Horizontal shutter with folding timber ladder, type LWF60

**Sponsor:** FAKRO Sp. z o.o.  
Wegierska 144a  
33-300 Nowy Sacz  
Poland

**Prepared by:** FIRES, s.r.o.  
Approved Body No. SK01  
Osloboditeľov 282  
059 35 Batizovce  
Slovak Republic

**Task No.:** PR-24-0053/01

**Date of issue:** 07. 03. 2024

Reports: 2  
Copy No.: 2

**Distribution list:**

Copy No. 1 FAKRO Sp. z o.o., Wegierska 144a, 33-300 Nowy Sacz, Poland  
Copy No. 2 FIRES, s. r. o., Osloboditeľov 282, 059 35 Batizovce, Slovak Republic

This expert judgement report with classification may only be used or reproduced in its entirety.



## 1. INTRODUCTION

This expert judgement report with classification defines the resistance to fire classification assigned to Horizontal shutter with retractable steel stairs, type LMF60, Horizontal shutter with retractable scissor steel stairs, type LSF60, Horizontal shutter with retractable timber stairs, type LWF60.

This expert judgement report defines field of application which is outside the field of direct application according test standard or outside the field of extended application according to relevant extended application standard. This expert judgement expresses the opinion of the FIRES and is based on the experience or internal rules of FIRES.

This expert judgement was elaborated on the basis of Fire resistance expert judgement report with classification No. FIRES-JR-025-20-NURE, issued by FIRES, s.r.o. on 04. 06. 2020.

This new document contains a constructional change - replacement of the SJ521 gasket for an alternative gasket. The change is described in cl. 2.2 of this document.

## 2. DETAILS OF CLASSIFIED PRODUCT

### 2.1 GENERAL

The elements, Horizontal shutter with folding steel ladder, type LMF60, Horizontal shutter with folding scissor steel ladder, type LSF60 and Horizontal shutter with folding timber ladder, type LWF60, are used as non-loadbearing horizontally oriented shutters with fire separating function from below. The products are installed in the ceiling of family houses, administrative and multifunctional buildings.

Normally each of the products is maintained in the closed position, without a lock. In the closed position the leaf is pressed (via springs) against the gaskets in the shutter frame. Once the leaf is tilted, the force decreases and the user can operate it with a less effort. The leaf is fitted with a holder that allows the hook-end of a rod to be attached. To open the shutter, it is needed to pull the holder by means of the rod and overcome the force the leaf is retained with.

### 2.2 PRODUCT DESCRIPTION

The elements, Horizontal shutter with folding steel ladder, type LMF60, Horizontal shutter with folding scissor steel ladder, type LSF60 and Horizontal shutter with folding timber ladder, type LWF60, consist of a shutter frame and a shutter leaf with a ladder.

Individual types of product (LWF, LMF, LSF) differ from each other only by the ladder type.

#### Dimensions

Overall dimensions	(1422 x 840) mm (height x width)
Dimensions of the shutter leaf	(1396 x 814 x 85) mm (height x width x thickness) *
Dimensions of the shutter opening	(1382 x 800) mm (height x width)
Weight of shutter	29,6 kg

\*NOTE: There was found a discrepancy between the shutter leaf dimensions (1397 x 815 x 85) mm stated cl. 2 of the test report [1] (see cl. 3.1 of this document) and the shutter leaf dimensions (1396 x 814 x 85) mm stated in sponsor drawings attached to that test report. At the request of sponsor the dimensions according to the drawings are used for classified product. Conditions for gap width are given in cl. 6.2 of this document.

#### Shutter frame

The shutter frame is made of pinewood slabs with a cross section of (220 x 20) mm (width x thickness) and an average bulk density of 520 kg/m<sup>3</sup> (manufacturer: STOLART Sp. z o.o.). The slabs are connected using a glue of type JOWACOLL 103.15 and staples (3 pieces in each corner).

NOTE: The average density of pinewood in accordance with EN 350: 2016.

Dimensions of the shutter frame rebate are of (30 x 11) mm; within the rebate a groove of (4 x 6) mm for TPS gasket of type SJ521 (manufacturer: AiB Sp. z o.o., Poland) is milled. Around the inner perimeter two grooves for santropene TPV gaskets of type SJ531 and SJ 541 (manufacturer: AiB Sp. z o.o., Poland) are milled.



- TPV gasket SJ531
- TPV gasket SJ541
- TPS gasket SJ521  
alternatively SEBS gasket 18375ZZ

Alternatively

Within the groove of (4 x 6) mm a SEBS gasket with index 18375ZZ (manufacturer: PlastArte Sp. z o.o., Poland or AiB Sp. z o.o., Poland) is applied instead of the TPS gasket SJ521.

**Shutter leaf**

- leaf frame - made of pinewood profiles (manufacturer: STOLART Sp. z o.o) with an average bulk density of 520 kg/m<sup>3</sup>; cross sections are as follows:  
 (79 x 41) mm – perimeter profiles;  
 (79 x 43) mm – intermediate transverse profiles.

NOTE: The average density of pinewood in accordance with EN 350: 2016.

The profiles are glued together with glue of type JOWACOLL 103.15.

The transverse profiles are placed in 74 mm, 239 mm, 884 mm from the back edge of the shutter leaf.

Dimensions of the leaf rebate are of (12 x 49) mm; within the rebate a groove of (20 x 2) mm for intumescent tape is milled.

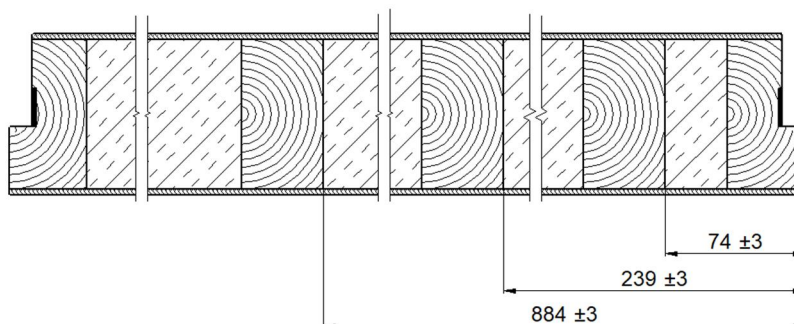

- core – mineral wool board, type ROCKLIT 150, 79 mm thick, with bulk density 150 kg/m<sup>3</sup> (manufacturer: Rockwool).



- facing – HDF board 3 mm thick, with bulk density (820 – 860) kg.m<sup>-3</sup> (manufacturer: Kronospan Szczecinek Sp.z o.o., Poland), glued to both sides of the leaf frame and the core using JOWACOLL 103.15, density 1,10 g.cm<sup>-3</sup> (manufacturer: JOWAT AG, Germany).



**Intumescent tape**

Promaseal PL, (2 x 20) mm (thickness x width) (manufacturer: PROMAT GmbH) around the perimeter of shutter leaf frame in the milled groove of (20 x 2) mm.

**Hinges**

Lever mechanism consists of

- upper crossbar complete, type 12726A3 (manufacturer: Fakro Orbita Sp z o.o),
- lower crossbar complete, type 12588A3 (manufacturer: Fakro Orbita Sp z o.o),
- bracket of type 12796A1 (manufacturer: Fakro Orbita Sp z o.o),
- springs of type 14095A0 with max. force of 2530 N (manufacturer: Mazowianka Sp zo.o.).

The mechanism is fixed with screws (5 x 50) mm to the shutter leaf and with bolts (6 x 22) mm and (6 x 35) mm to the shutter frame.

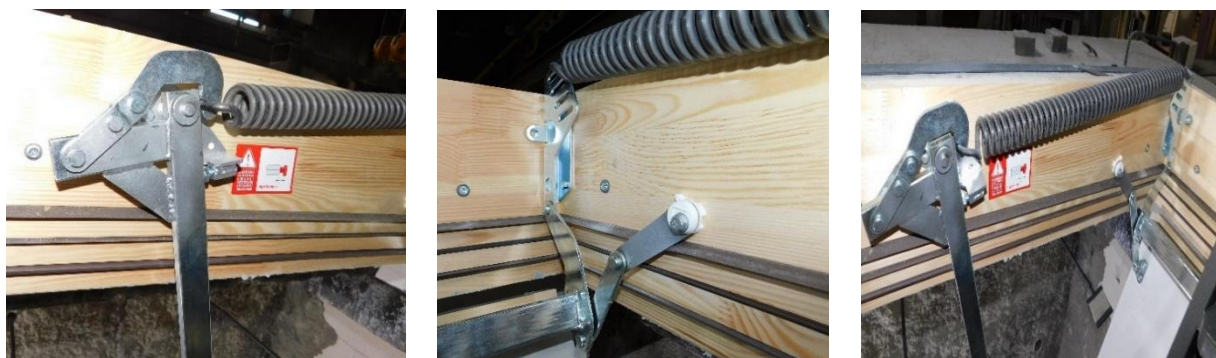

**Shutter holder / lock**

A shutter holder of type 12720A0, made from POM material, (manufacturer: Drok Sp. J. Krzysztof Popielnicki Ryszard Wrzesiński) is fixed with two screws of (3,5 x 25) mm to the bottom side of the shutter leaf in a milled counterbore,

and

a mortise lock, type Z093 (manufacturer: Firma Jania, Stanisław Jania), is placed on the lock edge of the shutter, 300 mm from the shutter edge to the centre of dead bolt. The lock cylinder - type M&D 9/25 (manufacturer: DELMET Senftleben Sp. J.).

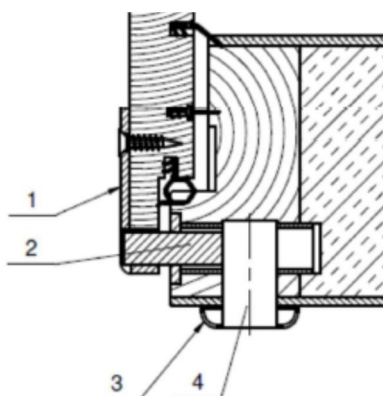

- 1 lock holder
- 2 lock
- 3 Euro cylinder cover
- 4 lock cylinder

Alternatively

A shutter holder of type 12720A0, made from POM material, (manufacturer: Drok Sp. J. Krzysztof Popielnicki Ryszard Wrzesiński) is fixed with two screws of (3,5 x 25) mm to the bottom side of the shutter leaf in a milled counterbore, without a lock.





## Ladder

### for LMF type

A 3-sections folding ladder, type 13045A3 (manufacturer: Fakro Orbita Sp z o.o.) is placed on shutter leaf surface from the top side and fixed to the lever mechanism. The mass of the ladder is max. of 22,2 kg.



### Alternatively

#### for LSF type

A steel ladder of scissor-type (manufacturer: Fakro Orbita Sp z o.o.). The mass of the ladder is max. of 20,8 kg.

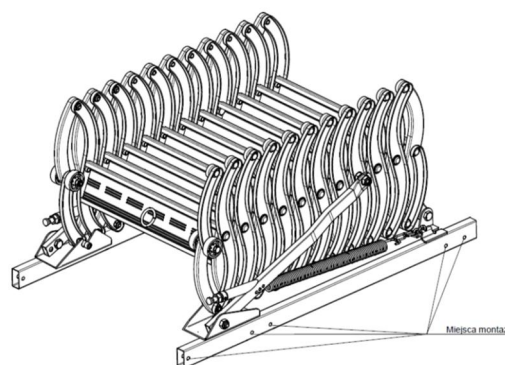

#### for LWF type

A 3-sections timber ladder (manufacturer: STOLART Sp. z o.o.). The mass of the ladder is max. of 11 kg.

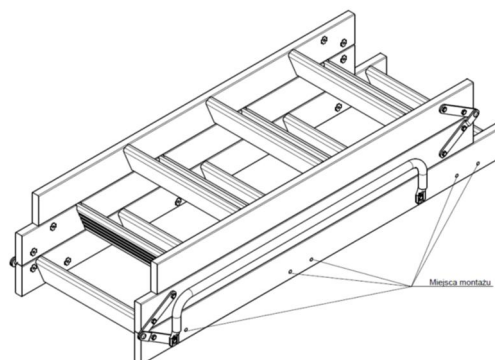

A 4-sections timber ladder (manufacturer: STOLART Sp. z o.o.). The mass of the ladder is max. of 13 kg.

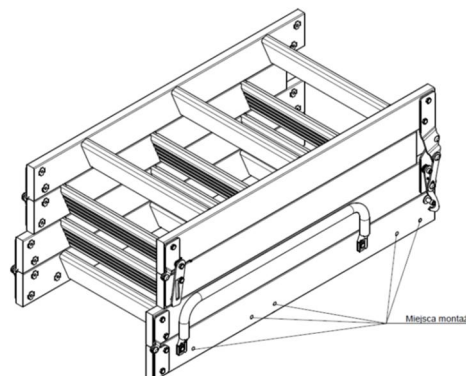



### 2.3 PRODUCT FIXATION

The product is installed within a ceiling of type Nida ES/CD/30 Ogien+ system, with a timber and steel framework.

The load-bearing timber framework is made of a fir wood. The joists with a cross section of (50 x 150) mm (width x height) and a bulk density of 320 kg/m<sup>3</sup> (manufacturer: DRENO – Produkcja wyrobów z drewna E. Dziurny Cz. Nowak s.j.) are spaced at maximum of 500 mm (distance between the centres). Each of the joists is on its ends fixed from both sides to the wall beam with cross section of (80 x 20) mm (width x thickness) via L-connectors with dimensions of (80 x 80 x 80 x 2) mm and screws of: (3,5 x 20) mm for L connectors to wall beam fixation and (3,5 x 45) mm for L connectors to timber joists fixation. The wall beam of (80 x 20) mm is fixed to the wall using nail dowels (6 x 80) mm in spacing of 500 mm.

On the timber joists bottom edge, Knauf CD steel profiles of (60 x 27 x 0,6) (manufacturer: KNAUF) are fixed with ES hangers (manufacturer: Knauf). The steel CD profiles centres are spaced at maximum of 400 mm. At the point of connection of CD profiles, connectors are used.

Two layers of gypsum plasterboards are fixed to the undersideside of the CD profiles. The first layer 15 mm thick is made of gypsum plaster board Knauf DFH2 (manufacturer: KNAUF) and the second layer 15 mm thick is made of gypsum plaster board Nida Ogien + (type DF) (manufacturer: Nida). Joints of gypsum boards within both layers are filled with mortar Nida Start.

The entire surface is covered with Nida Finisch gypsum mortar (manufacturer: Nida).

The ceiling cavity is filled with a mineral rock wool, type Toprock Super, 150 mm thick, with a bulk density of 40 kg/m<sup>3</sup> (manufacturer: Rockwool).

From above the ceiling is covered with one layer of OSB boards, 22 mm thick, with bulk density of 650 kg/m<sup>3</sup> (manufacturer: SWISS KRONO) which are fixed to timber joists with screws (3,5 x 45) mm with a spacing of 500 mm.

The shutter is installed to the ceiling construction using screws of (Ø 5 x 80) mm. In the gap between the shutter and the ceiling construction, in place of fixation, spacing wooden washers are used and around the opening for shutter the gypsum plaster board Nida Ogien + (type DF) 15 mm thick is applied.

The gap between the shutter frame and the ceiling construction is filled with a mineral wool with a bulk density of 60 kg/m<sup>3</sup> and sealed from both exposed and unexposed sides with a fire-resistant sealant of type MERCOR POLYLACK KG (manufacturer: Dunamenti Tűzvédelem Zrt., Hungary).

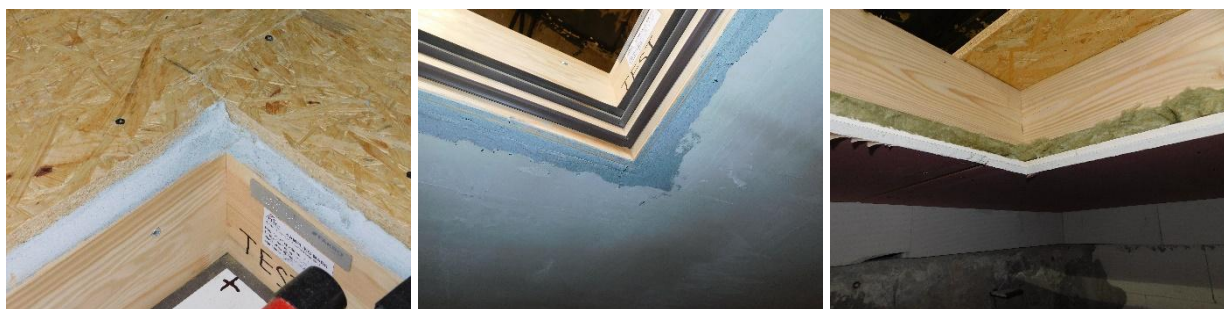

Around the perimeter of opening for the shutter, mineral rock wool of type Toprock Super, 30 mm thick, with a bulk density of 40 kg/m<sup>3</sup> (manufacturer: Rockwool) in width of 200 mm is applied.

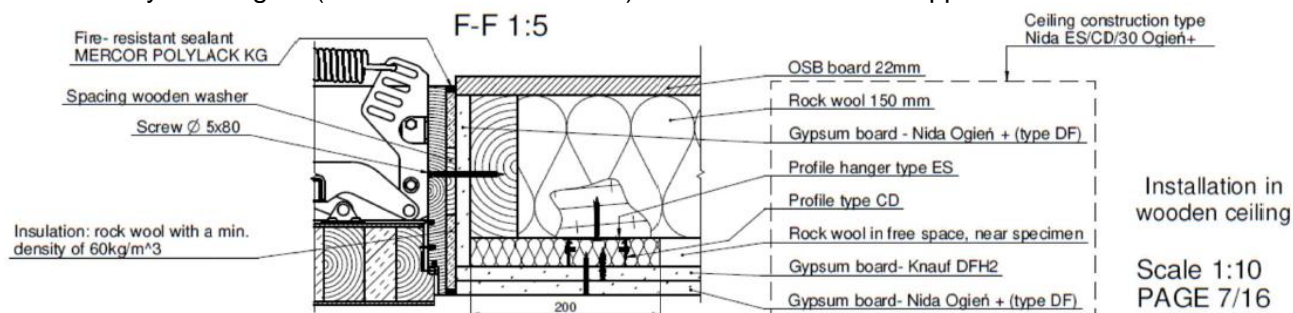

More detailed information about product construction is shown in drawings to test report [1] and [2] according to cl. 3.1 of this document.



### 3. TEST REPORTS AND EXTENDED APPLICATION REPORTS IN SUPPORT OF CLASSIFICATION

#### 3.1 TEST REPORTS AND EXTENDED APPLICATION REPORTS

No.	Name of laboratory	Name of sponsor	Test report No.	Date of the test	Test method
[1]	FIRES, s.r.o., Batizovce, SR	FAKRO Sp. z o.o., Nowy Sacz, Poland	FIRES-FR-162-19-AUNS	14. 11. 2019	EN 1364-2: 2018
[2]	FIRES, s.r.o., Batizovce, SR	FAKRO Sp. z o.o., Nowy Sacz, Poland	FIRES-FR-161-19-AUNS	16. 07. 2019	EN 1634-1: 2014+A1:2018

[1] - [2] Test specimens were conditioned according to EN 1363-1 before the fire resistance test

#### 3.2 TEST RESULTS

No./ Test method	Parameter	Results	
[1] EN 1364-2	applied load	22,2 kg via the ladder which is a part of the test specimen	
	supporting construction	ceiling made of Nida ES/CD/30 Ogien+ system, with a timber and steel framework	
	temperature curve	standard temperature time curve	
	loadbearing capacity	-	
	integrity	cotton pad	95 minutes
		gap gauges	95 minutes
		sustained flaming	95 minutes
	thermal insulation	l <sub>1</sub>	88 minutes*
		l <sub>2</sub>	95 minutes*
	radiation		95 minutes
	operability		passed (25 cycles)
	self closing		-
test specimen, orientation		wooden ceiling with horizontal shutter with folding steel ladder of type LMF60; opening of the leaf towards the furnace (fire form below, ladder on unexposed side)	
[2] EN 1634-1	applied load	22,2 kg via the ladder which is a part of the test specimen	
	supporting construction	ceiling rigid supporting construction made of aerated concrete blocks 150 mm thick with bulk density of 650 kg/m <sup>3</sup> ± 200 kg/m <sup>3</sup>	
	temperature curve	standard temperature time curve	
	loadbearing capacity	-	
	integrity	cotton pad	80 minutes
		gap gauges	81 minutes no failure
		sustained flaming	80 minutes
	thermal insulation	l <sub>1</sub>	74 minutes
		l <sub>2</sub>	80 minutes
	radiation		80 minutes
	operability		passed (25 cycles)
	self closing		-
test specimen, orientation		Shutter of LMF60 type; opening of the leaf towards the furnace (fire form below, ladder on unexposed side)	
* Although the test was carried out in accordance with EN 1364-2, the thermocouples on unexposed face of the shutter were arranged in accordance with EN 1634-1 (for normal and supplementary procedure).			



- [1] 97<sup>th</sup> minute because of integrity failure of test specimen
- [2] The test was discontinued in 82<sup>nd</sup> minute because of integrity failure of test specimen

**4. CHANGES OF THE PRODUCT OR END USE CONDITIONS OUTSIDE OF THE FIELD OF DIRECT OR EXTENDED APPLICATION**

Following changes of the product or end use conditions were permitted:

1. The alternative ladders according to cl. 2.2 of this document.
2. Application of alternative mineral wool (instead of Rockwool ROCKLIT 150) used as an insulation core in the hatch.
3. The mortice lock used on the shutter leaf in test [1] may be omitted and the shutter leaf may be fitted only with the shutter holder of type 12720A0, made from POM material (without a lock).
4. Application of the alternative 18375ZZ gasket according to cl. 2.2 of this document

**5. ARGUMENTS IN FAVOR OF THE EXTENSION**

1. Each of the alternative ladders listed in cl. 2.2 of this document has a smaller weight than the ladder used in the test [1], the weight of tested ladder was of 22,2 kg. Each of the alternative ladders is fixed to the leaf and frame by the same way as that in the test [1]. Under those conditions it can be supposed that the fire resistance of the shutter is not decreased.  
The ladder type defines also the shutter type designation (see cl. 2.2 of this document).
2. It is allowed to apply an alternative mineral wool (instead of Rockwool ROCKLIT 150) in the core of the shutter leaf provided that the thickness of alternative mineral wool is of 79 mm (the same as tested) and its bulk density is of (150 - 180) kg/m<sup>3</sup>, the reaction to fire classification acc. to EN 13501-1 is A1 and the melting temperature of the fibres of the alternative mineral wool is at least the same as that for tested mineral wool.
3. It is allowed to fit the shutter leaf only with the shutter holder of type 12720A0 (without the lock) based on the test [2] where such a situation was tested while the test specimen was installed in a rigid supporting construction. The test results given in cl. 3.2 of this document show that the test specimen in test [2] met the integrity criterion for 80 minutes, insulation criterion for normal procedure for 80 minutes, insulation criterion for supplementary procedure for 74 minutes and the test [2] was terminated at 81<sup>st</sup> minute; therefore, when the described change is to be applied the classification of product has to be modified in accordance with cl. 6.1.
4. The alternative SEBS gasket 18375ZZ may be used instead of the tested TPS gasket based on the following reasons
  - in accordance with FAKRO declaration, the dimensions of both gasket types are comparable, so the amount of flammable material will not increase;
  - in accordance to FAKRO declaration, both TPS and SEBS materials are of reaction to fire class F;
  - the gasket in question is installed in the shutter frame rebate between the shutter frame and shutter leaf, and above this gasket, the intumescent tape Promaseal PL (2 x 20) mm is applied on the shutter leaf edge; it is expected that in a case of fire the intumescent tape will work in the same way as in the fire test and the integrity criterions can be met for the same period as in the test;
  - in the test [2] the integrity criterions were met for 80 minutes, i.e. there is an overrun of 20 minutes for classification period of 60 minutes, such an overrun represents 33 % of classification period.

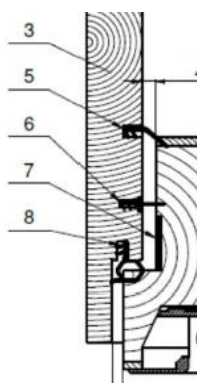

- 7 intumescent tape
- 8 gasket in question

Note: Other items according to test report [1]

**Position of the gasket and intumescent tape**

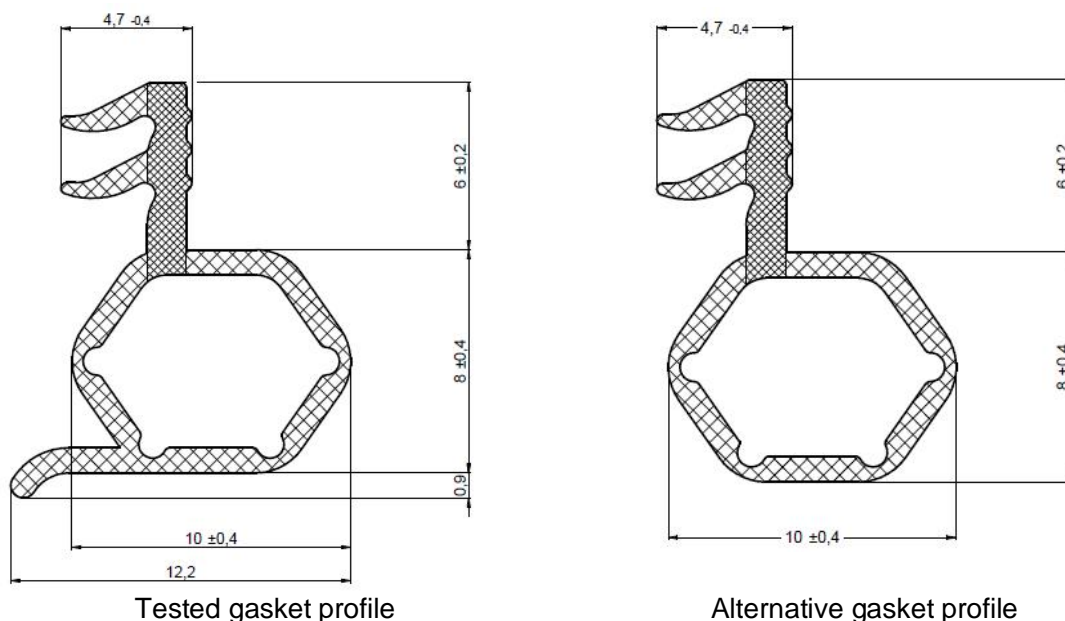

Comparison of tested and alternative gaskets

**6. CLASSIFICATION AND FIELD OF APPLICATION**

The element, Horizontal shutter with retractable steel stairs, type LMF60, Horizontal shutter with retractable scissor steel stairs, type LSF60, Horizontal shutter with retractable timber stairs, type LWF60, is classified according to the following combinations of performance parameters and classes as appropriate.

Orientation	Fire resistance classification
Fire from below (ladder on unexposed side)	<b>E 60; EI<sub>1</sub> 60; EI<sub>2</sub> 60; EW 60</b>

**6.2 FIELD OF APPLICATION**

This classification is valid for the following end use applications:

Materials and construction	<ul style="list-style-type: none"> <li>- it is allowed to realize the changes described in cl. 4 and 5 of this document;</li> <li>- the thickness of the shutter leaf shall not be reduced nor increased,</li> <li>- the density of the leaf core (mineral wool) shall not be reduced and may be increased according to cl 5 of this document (max. up to 180 kg/m<sup>3</sup>); the total increase in weight shall not be greater than 25 %;</li> </ul> <p>NOTE: The manufacturer is responsible for compensation of increased leaf weight using springs with the force appropriate for increased leaf weight (the leaf weight may be increased by max of 25 %).</p> <ul style="list-style-type: none"> <li>- for timber-based board products (e.g. particle board, blockboard etc.), the composition (e.g. type of resin) shall not change from that tested;</li> <li>- the cross-sectional dimensions and/or the density of the shutter frame shall not be reduced but may be increased;</li> <li>- the number, size, location and orientation of any joints in the timber framing shall not be changed;</li> </ul>
Decorative finishes	- decorative laminates and timber veneers up to 1,5 mm thickness may be added to the faces (but not the edges) of shutter;
Fixings	- the number of fixings used to attach the product to supporting constructions may be increased but shall not be decreased and the distance between fixings may be reduced but shall not be increased;

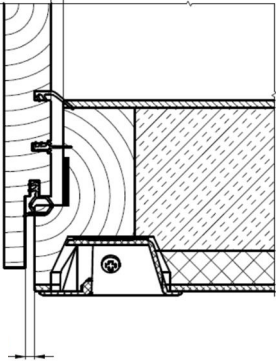

Permissible size variations	<ul style="list-style-type: none"> <li>- size increase is not permitted;</li> <li>- unlimited size reduction is permitted;</li> </ul>					
Supporting construction	<ul style="list-style-type: none"> <li>- the product may be mounted into a ceiling of type Nida ES/CD/30 Ogien+ system, with a timber and steel framework (see cl. 2.3) using the same fixing method as described in cl. 2.3 of this document;</li> <li>- the product may be mounted into a timber ceiling (with timber framework) with overall thickness minimum of 232 mm provided that:                             <ul style="list-style-type: none"> <li>- the additional insulation made from rock wool 30 mm thick, with a bulk density of 40 kg/m<sup>3</sup> in area of 200 mm around the aperture for shutter is remained;</li> <li>- on the bottom of ceiling there are minimum of 2 layers of fire gypsum plasterboard according to EN 520:2004+A1:2009, each layer is min of 15 mm thick and the gypsum plasterboard is of type DF or DFH2, the individual layers are fixed using an appropriate method;</li> <li>- the stiffness of the ceiling is at least the same as that of the tested one;</li> <li>- fire resistance of the ceiling shall be at least the same as that declared for the shutter (the ceiling shall be tested and classified separately).</li> </ul> </li> </ul>					
Gaps		<p>Maximal permitted lower gaps:</p> <table border="0" style="width: 100%;"> <tr> <td style="padding-right: 20px;">Longer edges</td> <td style="text-align: right;">4,7 mm</td> </tr> <tr> <td>Shorter edges</td> <td style="text-align: right;">4,3 mm</td> </tr> </table>	Longer edges	4,7 mm	Shorter edges	4,3 mm
Longer edges	4,7 mm					
Shorter edges	4,3 mm					



## 7. LIMITATIONS

This classification document does not represent type approval or certification of the product.

The classification is valid until 07. 03. 2029 provided that the product, field of application and standards and regulations are not changed.

Approved by:

Ing. Marek Gorlický  
*Head of the Testing Laboratory*

Prepared by:

Ing. Anna Rástocká  
*Technician of the Testing Laboratory*

